

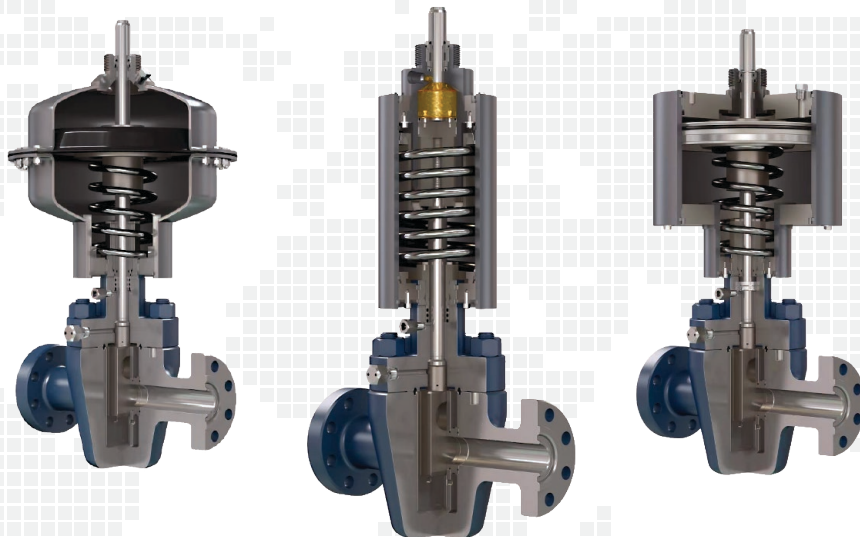

HYDRAULIC / PNEUMATIC



Actuators & Surface Safety Valves



Including: Accessories & Alternative Configurations

ENGINEERED FOR OPERATIONAL EXCELLENCE



Omni Valve is committed to delivering the highest-quality actuator and surface safety valve solutions. We focus our efforts on working closely with each customer to understand their unique requirements and develop long-term supply relationships.

Our actuator and surface safety valve products are engineered for operational excellence, with special attention given to the unique requirements of specific customers, projects or regions. This often involves customizing individual actuators, designing specific procurement programs or providing structured design and/or manufacturing services to our customers.

Omni Valve is certified to API/ISO standards and adheres to strict HSE standards in all segments of the business.

Table of Contents

Introduction	2
Actuator Applications	4
Hydraulic Actuation Products	6
Pneumatic Actuation Products	7
Mode of Operation – Single Acting	8
Mode of Operation – Double Acting	9
Pneumatic Actuation Products	
Model DX - Diaphragm	10
Tandem Model DX	14
Model PX - Piston	16
Model PMX - Piston (Integrated Manual Override)	20
Hydraulic Actuation Products	
Model HX - Piston	24
Model HWX - (Wire Cutting)	28
Model HDX - Piston (Double Acting)	32
Bonnet Specifications / Hydraulic & Pneumatic	36
Actuator Accessories	
Manual Override	38
Fusible Manual Override	39
Shipping Cap	40
Fusible Lock Open Cap	41
Limit Switch & Position Indicator	42
Hydraulic Control Solutions	
Model EX – Self-Contained Hydraulic Control System	44

ACTUATOR & SURFACE SAFETY VALVE

Fail Safe Applications

Omni actuators and surface safety valves are used in a variety of oil and gas production and pipeline applications. Some common positions within simple production tree and pipeline applications are depicted below. For additional options please contact Omni Valve.

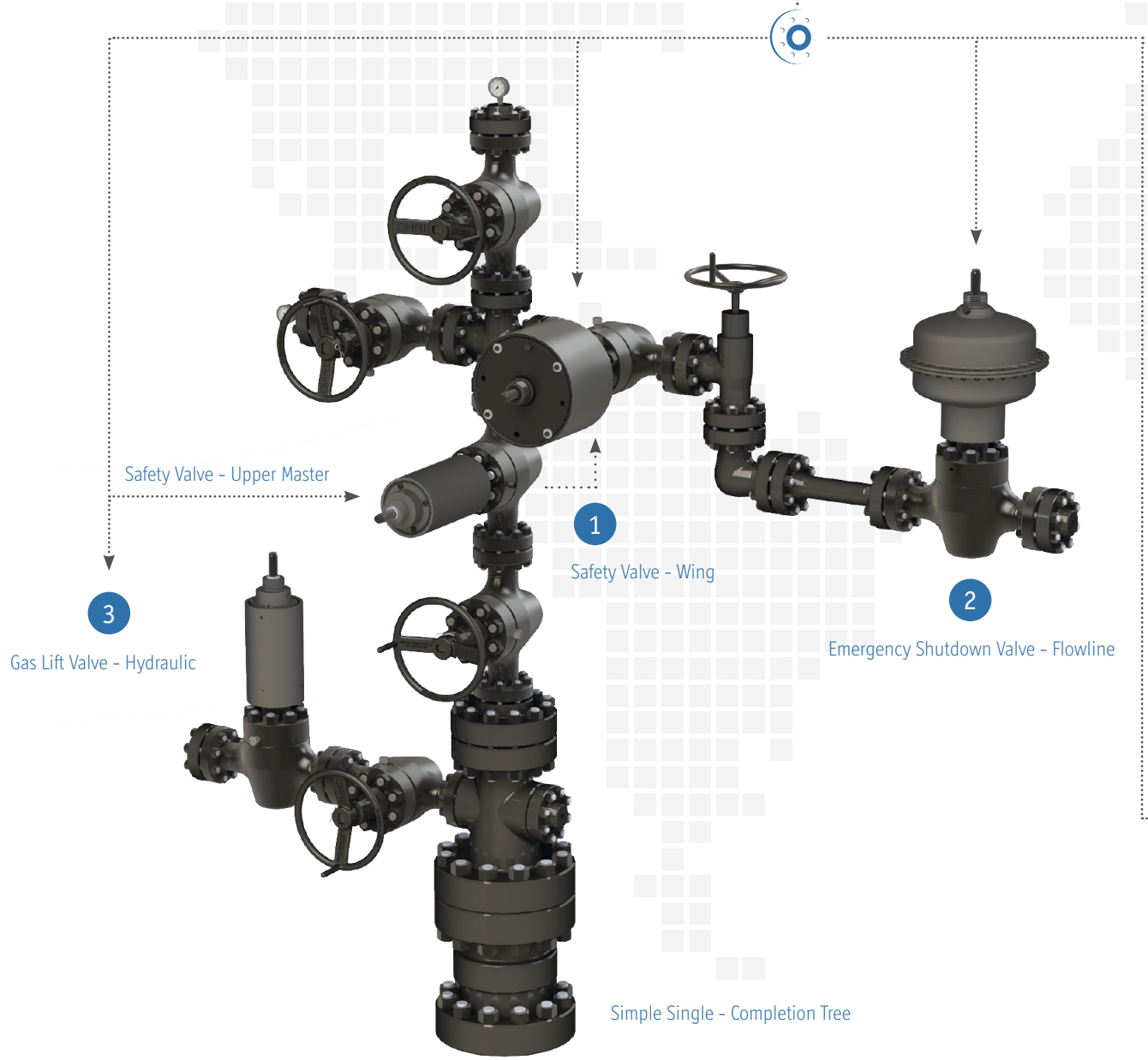
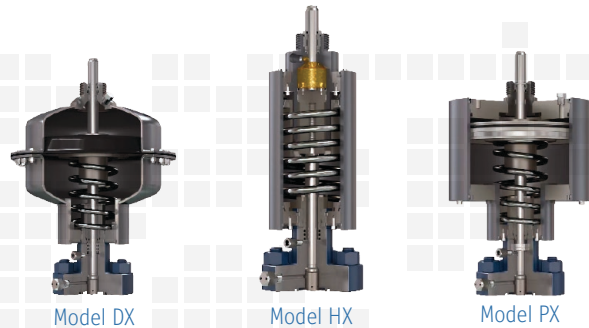

ACTUATOR & SURFACE SAFETY VALVE

Fail Safe Applications



Omni offers a complete line of actuator and valve solutions that are appropriate for most on and off-shore surface applications. Selection of the appropriate actuator type, size and position within the application is the responsibility of the user and is heavily dependent on wellsite layout, production tree configuration, service conditions, available power sources, pipeline design and other factors.

Some common uses are:

1 PRODUCTION TREE SAFETY VALVE – UPPER MASTER OR WING

Omni pneumatic and hydraulic actuated valves are commonly used as safety valves in the main run or on the wing of oil and/or natural gas production tree.

2 EMERGENCY SHUTDOWN VALVE – DOWNSTREAM OF THE CHOKE

Omni pneumatic and hydraulic actuated valves are also used as automatic shutdown valves on the flowline for protection of separators, storage tanks or other equipment downstream of the choke.

3 SHUTDOWN OR CONTROL VALVE – GAS LIFT APPLICATIONS

Omni hydraulic actuated valves are used as shutdown or control valves in intermittent or continuous flow annulus, tubular or other gas lift applications.

4 SHUTDOWN VALVE – PIPELINE

Omni pneumatic and hydraulic actuated valves are commonly used as safety shutdown valves in pipeline applications requiring fail-safe valves at specific positions in the line.

5 SHUTDOWN VALVE – GAS OR OIL STORAGE

Omni pneumatic and hydraulic actuated valves are commonly used as safety shutdown valves in storage applications to protect storage tanks or domes.

OTHER APPLICATIONS: Omni also provides actuators for use in drilling manifolds, choke and kill manifolds, wireline operations and other applications.

See specific product line information in this brochure or contact Omni Valve for more information.

Pipeline and Tank Storage



HYDRAULIC ACTUATORS

Product Line

Omni offers hydraulically actuated valve assemblies ready to deploy directly into service, or as actuated bonnet assemblies ready to mount on valves from other manufacturers. Omni also offers a full range of accessories including standard and fusible manual overrides, position indicators, and fusible lock open devices.

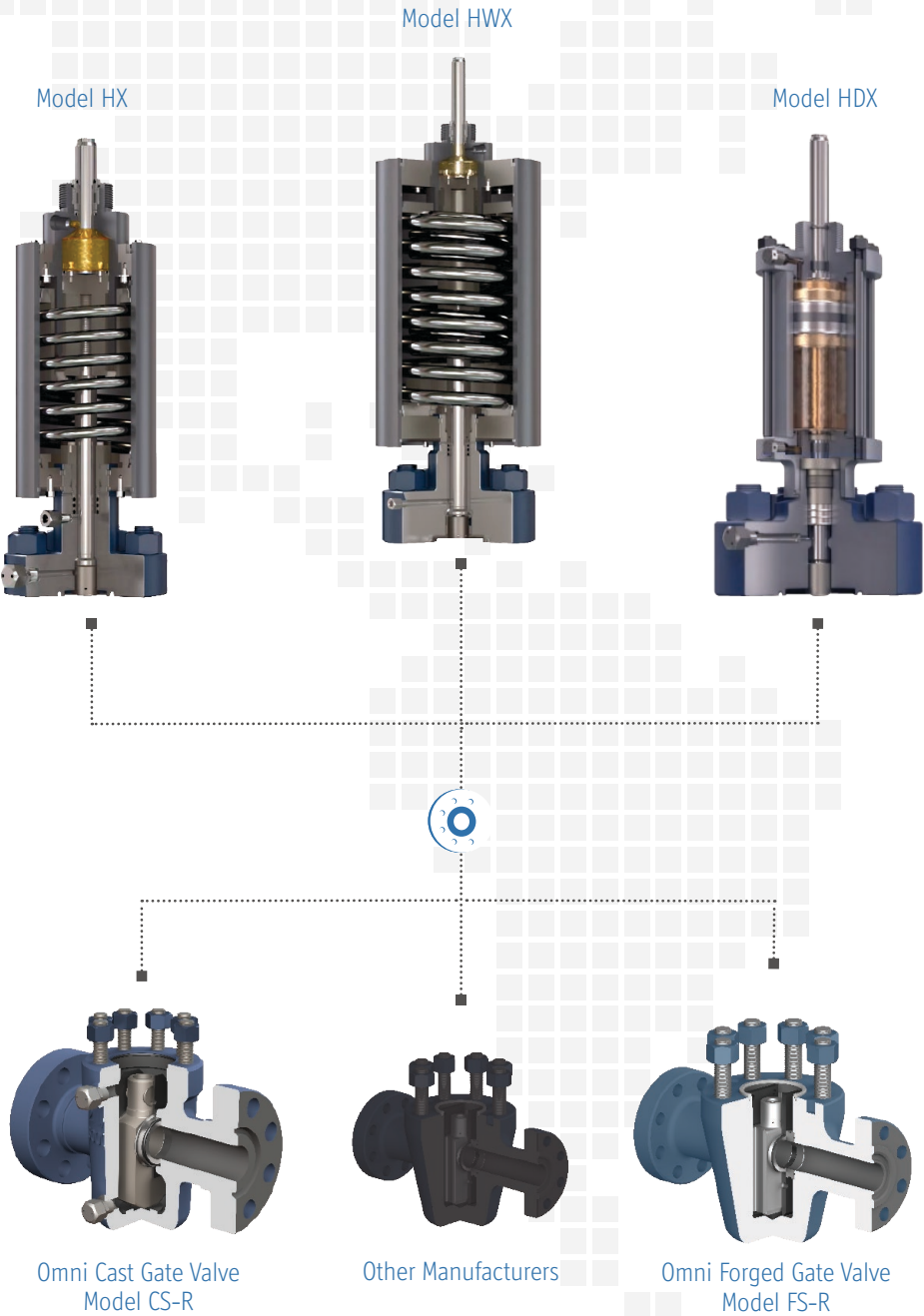

PNEUMATIC ACTUATORS

Product Line



Omni offers pneumatically actuated valve assemblies ready to deploy directly into service, or as actuated bonnet assemblies ready to mount on valves from other manufacturers. Omni also offers a full range of accessories including standard and fusible manual overrides, position indicators, and fusible lock open devices.



Pneumatic

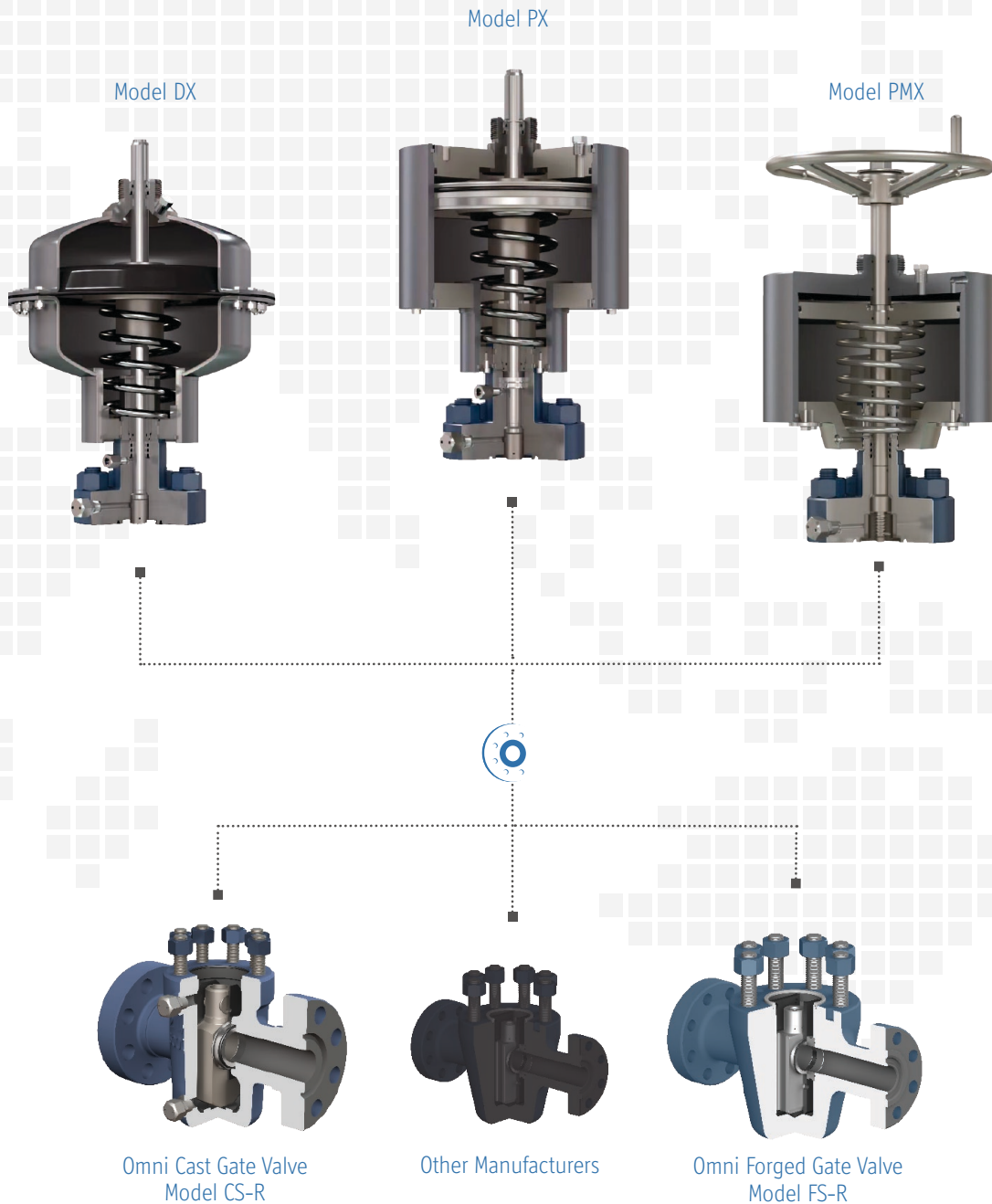

FAIL SAFE – ACTUATOR OPERATION

Fail “closed” operation depicted. *Fail “open” operation available upon request.*



Hydraulic

&



Pneumatic

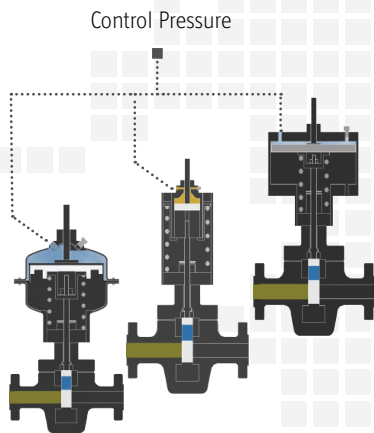

STAGE 1

When no control pressure is applied to actuator, valve is in closed position (Gate all the way up)

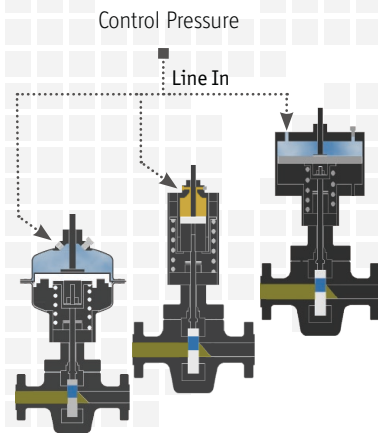

STAGE 2

Upon application of adequate control pressure to the actuator port, valve begins to open (Gate moves down)

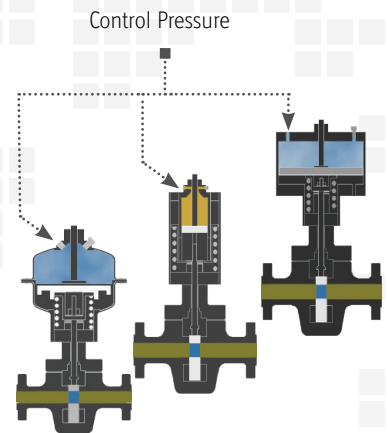

STAGE 3

With continued application of adequate control pressure, valve moves to the fully open position (Gate all the way down)

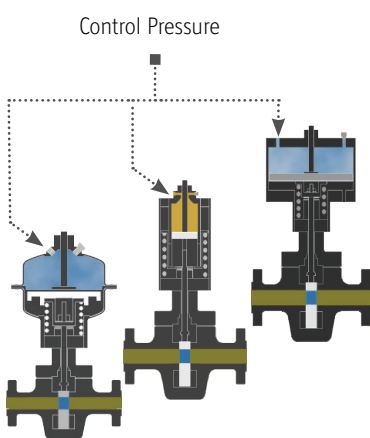

STAGE 4

Valve remains in fully open positions as long as adequate control pressure is present (Gate all the way down)

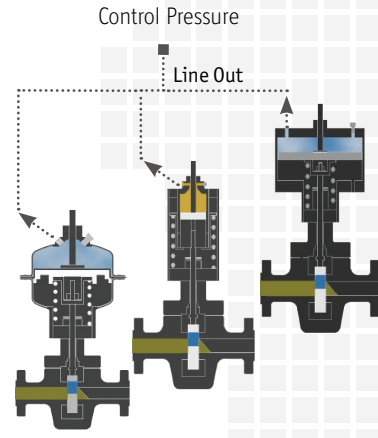

STAGE 5

Upon loss of control pressure, valve begins to close (Gate moves up)

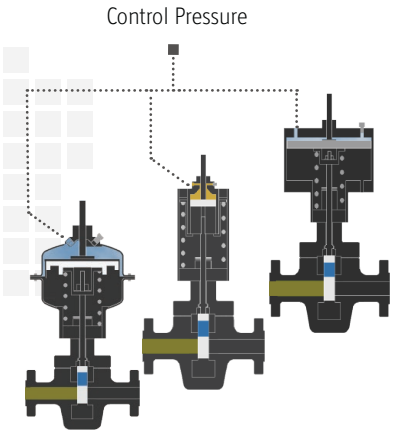

STAGE 6

Valve fully closes and remains closed until application of control pressure to the upper actuator port (Gate all the way up)

DOUBLE ACTING – ACTUATOR OPERATION

Open and Close operation depicted



Hydraulic

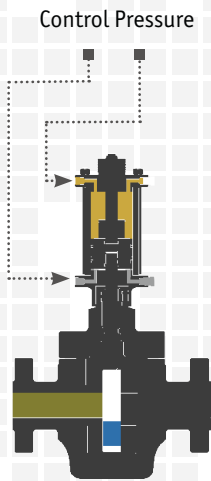

STAGE 1

When no control pressure is applied to actuator, valve is in closed position (Gate all the way down)

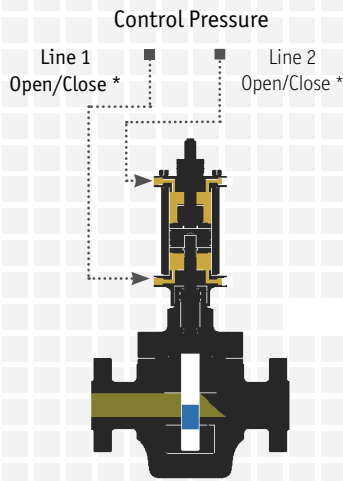

STAGE 2

Upon application of adequate control pressure to the actuator, valve begins to open (Gate moves up)

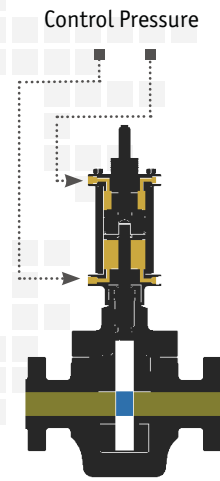

STAGE 3

With continued application of adequate control pressure, valve moves to the fully open position (Gate all the way up)

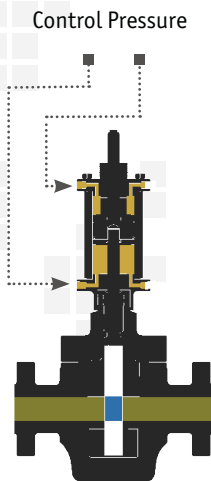

STAGE 4

Valve remains in fully open position as long as adequate control pressure is present (Gate all the way up)

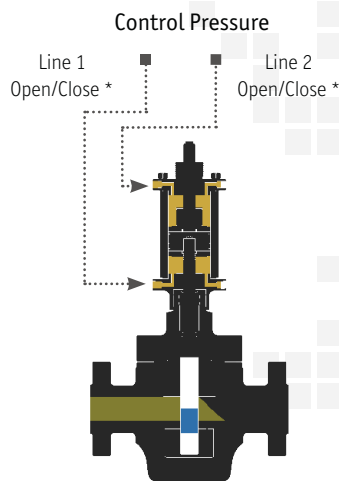

STAGE 5

Upon application of adequate control pressure, valve begins to close (Gate moves down)

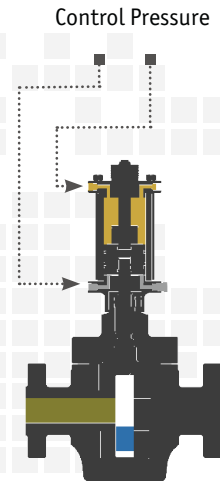

STAGE 6

Valve fully closes and remains closed until application of control pressure to the actuator (Gate all the way down)

* Dependent upon configuration

MODEL DX

Diaphragm Actuator



Available Sizes

Model	Size	Stroke
DX 10	10"	Up to 2 1/16" bore
DX 12	12"	Up to 3 1/8" bore
DX 15	15"	Up to 4 1/16" bore
DX 18	18"	Up to 5 1/8" bore
DX 20	20"	Up to 4 1/16" bore

Intro

Omni Model DX pneumatic diaphragm actuators are designed to operate surface safety or shutdown valves on oil & gas wellhead, transmission, storage, manifold or other applications where fail-safe capability is required.

Model DX actuators can be used for land or off shore installations and are engineered to provide reliable service in a variety of operating conditions.

Omni can provide Model DX actuators already mounted on valves and ready to deploy, or as actuated bonnet assemblies ready to mount on valves from other manufacturers.

Additionally, Omni offers a full range of accessories including standard & fusible manual overrides, position indicators and fusible lock open devices.

Features

Flexibility

Model DX actuators can be adapted to operate valves from any manufacturer (interface information is required) and can be assembled in single or tandem (double actuator) configurations if required by field conditions.

Over-Pressure Protection

Model DX actuators come equipped with pressure relief devices to protect personnel and guard against damage to the actuator in case of an over pressure condition. The pressure relief device is easily inspected and is field-replaceable.

Orientation, Rotation & Ease of Piping

Model DX actuators have pressure inlet and outlet ports located at an angle in the top plug assembly to facilitate proper piping orientation based on field conditions. Once proper orientation has been achieved, the actuator's lower bonnet retaining ring can be locked into place to prevent accidental rotation of the actuator while in service.

Backseat & Packing Integrity

Model DX actuators incorporate bonnet assemblies that have an integrated metal-to-metal backseat. A bonnet fitting can also be used to relieve any pressure that might be trapped between the backseat and stem packing after the backseat operation. A tattletale weep port is located above the packing to provide visual confirmation of stem seal integrity during operation. All Model DX ports can be used to pipe fugitive emissions to a containment vessel, if required.

Corrosion Protection

Model DX actuator housings are internally and externally coated to prevent corrosion due to environmental conditions. All internal components are either stainless steel or are coated to prevent corrosion due to any contamination that might be present in the control pressure source.

Maintenance

Model DX actuators are lightweight and designed for ease of maintenance. All non-metallic seals and other parts are easily replaceable.

INTERNAL CONFIGURATION & Redress Kit Parts

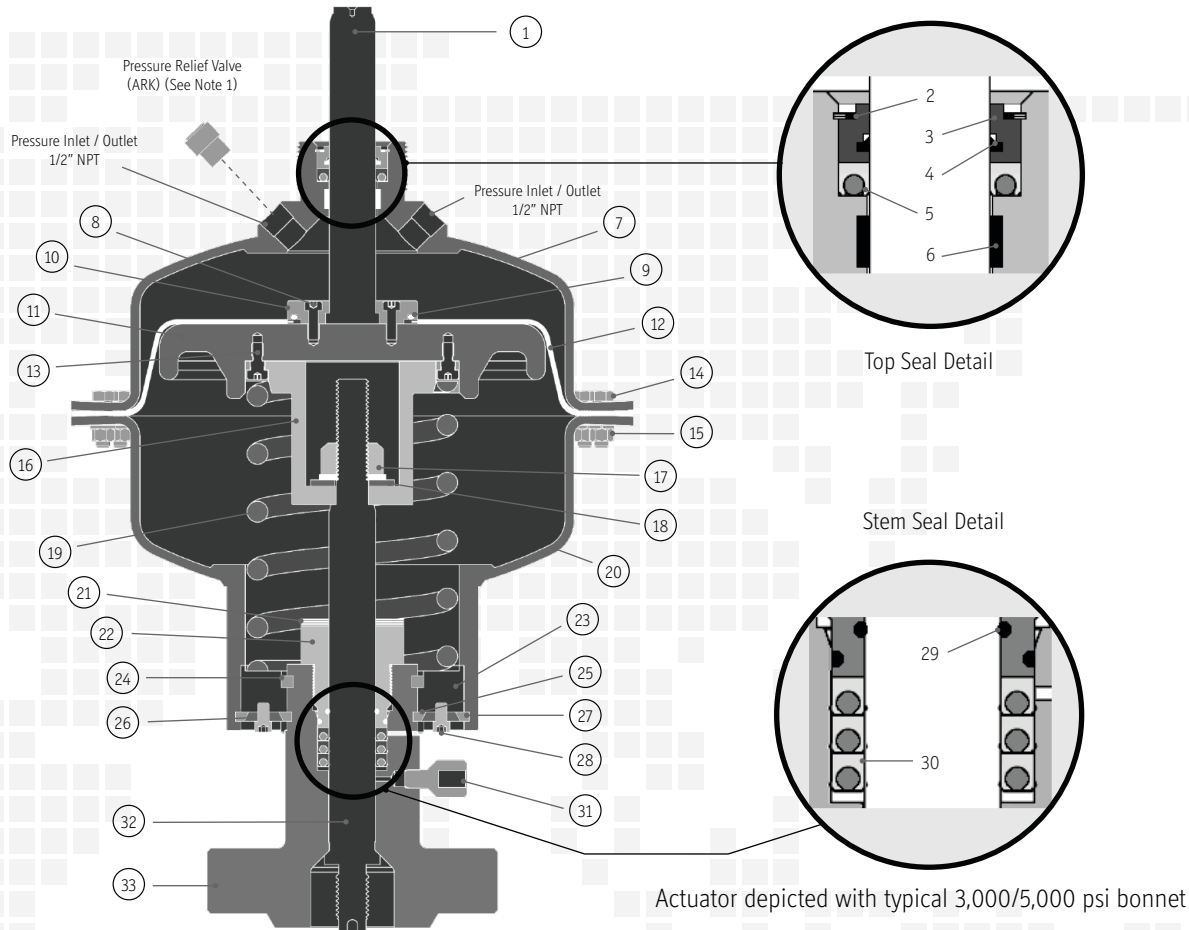

Internal Parts - Non Redress Kit Items

Component	Description	Qty
1	Upper Shaft	1
7	Upper Housing	1
8	Upper Shaft Retainer Bolts	6
10	Upper Shaft Retainer	1
11	Diaphragm Retainer Plate	1
13	Spring Retainer Cup Bolt	2
16	Spring Retainer Cup	1
17	Stem Nut - Nylock	1
18	Stem Washer	1
19	Spring	1
20	Lower Housing	1
21	Drift Shims	3
22	Packing Retainer	1
23	Bonnet Ring	1
31	Bonnet Vent Fitting	1
32	Operating Stem (See Note 3)	1
33	Bonnet (See Note 3)	1

ARK = Actuator Redress Kit Items

Component	Description	Qty
2	Shaft Seal Retainer Ring	1 (ARK)
3	Shaft Seal Retainer	1 (ARK)
4	Rod Wiper	1 (ARK)
5	Upper Shaft Seal	1 (ARK)
6	Wear Band	1 (ARK)
9	Upper Shaft Retainer O-Ring	1 (ARK)
12	Diaphragm	1 (ARK)
14	Housing Bolts (See Note 2)	Varies (ARK)
15	Housing Washer / Nuts (See Note 2)	Varies (ARK)

AAK = Actuator Attachment Kit Items

Component	Description	Qty
24	Upper Bonnet Retaining Ring	2 (AAK)
25	Lower Bonnet Retaining Ring	2 (AAK)
26	Bonnet Clamp Ring	2 (AAK)
27	Spring Retainer Snap Ring	4 (AAK)
28	Bonnet Clamp Ring Bolts	4 (AAK)

BRK = Bonnet Redress Kit Items

Component	Description	Qty
29	Packing Retainer O-Ring	2 (BRK)
30	Stem Seals	3 (BRK)

Note 1: Pressure relief valve is set at 170 psi. Valve will relieve any pressure above 170 psi inside the upper housing and then automatically reset.

Note 2: The number of housing bolts, washers and nuts depends on actuator model. DX-10 (24) / DX-12 (24) / DX-15 (32) / DX-18 (48) / DX-20 (60)

Note 3: Represents the number of bonnet clamp ring bolts in standard configurations of Omni's Model DX Actuator. Tandem applications or custom configurations of Model DX Actuators could contain different quantities of this item. In these cases, the number of bonnet clamp ring bolts will be identified in the data book provided with the order.

Note 4: The specific configuration of bonnet and operating stem is dependent on valve design. Omni Model DX actuators can be adapted to operate valves from any valve manufacturer.

ACTUATOR CONTROL PRESSURES

Model DX



Bore Size	Working Pressure	Actuator Model									
		DX-10		DX-12		DX-15		DX-18		DX-20	
		Equation	PSI	Equation	PSI	Equation	PSI	Equation	PSI	Equation	PSI
2 1/16"	2,000	0.028 x WP + 6 psi =	62	0.018 x WP + 4 psi =	40	0.015 x WP + 3 psi =	33				
2 9/16"	2,000			0.025 x WP + 5 psi =	55	0.021 x WP + 3 psi =	45	0.015 x WP + 2 psi =	32		
3 1/8"	2,000			0.035 x WP + 5 psi =	75	0.031 x WP + 4 psi =	66	0.021 x WP + 3 psi =	45	0.017 x WP + 2 psi =	36
4 1/16"	2,000									0.027 x WP + 3 psi =	57
5 1/8"	2,000									0.048 x WP + 3 psi =	99
7 1/16"	2,000										
2 1/16"	3,000	0.028 x WP + 6 psi =	91	0.018 x WP + 4 psi =	58						
2 9/16"	3,000			0.025 x WP + 5 psi =	80	0.015 x WP + 3 psi =	48				
3 1/8"	3,000			0.035 x WP + 5 psi =	110	0.021 x WP + 3 psi =	63	0.015 x WP + 2 psi =	47		
4 1/16"	3,000					0.031 x WP + 4 psi =	97	0.021 x WP + 3 psi =	66	0.017 x WP + 2 psi =	53
5 1/8"	3,000									0.027 x WP + 3 psi =	84
7 1/16"	3,000									0.048 x WP + 3 psi =	147
2 1/16"	5,000	0.028 x WP + 6 psi =	147	0.018 x WP + 4 psi =	94						
2 9/16"	5,000			0.025 x WP + 5 psi =	130	0.015 x WP + 3 psi =	78				
3 1/8"	5,000			0.035 x WP + 5 psi =	180	0.021 x WP + 3 psi =	105	0.015 x WP + 2 psi =	77		
4 1/16"	5,000					0.031 x WP + 4 psi =	159	0.021 x WP + 3 psi =	108	0.017 x WP + 2 psi =	87
5 1/8"	5,000									0.027 x WP + 3 psi =	138
7 1/16"	5,000	Under most circumstances a single DX actuator will not be sufficient - please contact Omni for options									
1 13/16"	10,000					0.013 x WP + 3 psi =	133	0.009 x WP + 2 psi =	92	0.007 x WP + 2 psi =	72
2 1/16"	10,000					0.014 x WP + 3 psi =	143	0.010 x WP + 2 psi =	102	0.008 x WP + 2 psi =	82
2 9/16"	10,000					0.016 x WP + 3 psi =	163	0.011 x WP + 2 psi =	112	0.009 x WP + 2 psi =	92
3 1/16"	10,000							0.015 x WP + 2 psi =	152	0.012 x WP + 2 psi =	122
4 1/16"	10,000	Under most circumstances a single DX actuator will not be sufficient - please contact Omni for options									
5 1/8"	10,000	Under most circumstances a single DX actuator will not be sufficient - please contact Omni for options									
7 1/16"	10,000	Under most circumstances a single DX actuator will not be sufficient - please contact Omni for options									
1 13/16"	15,000							0.009 x WP + 2 psi =	137	0.007 x WP + 2 psi =	107
2 1/16"	15,000							0.010 x WP + 2 psi =	152	0.008 x WP + 2 psi =	122
2 9/16"	15,000									0.011 x WP + 2 psi =	167
3 1/16"	15,000	Under most circumstances a single DX actuator will not be sufficient - please contact Omni for options									
4 1/16"	15,000	Under most circumstances a single DX actuator will not be sufficient - please contact Omni for options									
5 1/8"	15,000	Under most circumstances a single DX actuator will not be sufficient - please contact Omni for options									
7 1/16"	15,000	Under most circumstances a single DX actuator will not be sufficient - please contact Omni for options									

Standard Actuator Specifications

Maximum Operating Pressure (See Note 1)	170 PSI	Pressure relief device on actuator is set at 170 PSI
API Material Class	AA / BB / CC	Not appropriate if control source contains H2S (is sour)
API Temperature Rating	P (-20 F to 180 F)	(-29 C to 82 C)

DIMENSIONAL DATA

Model DX

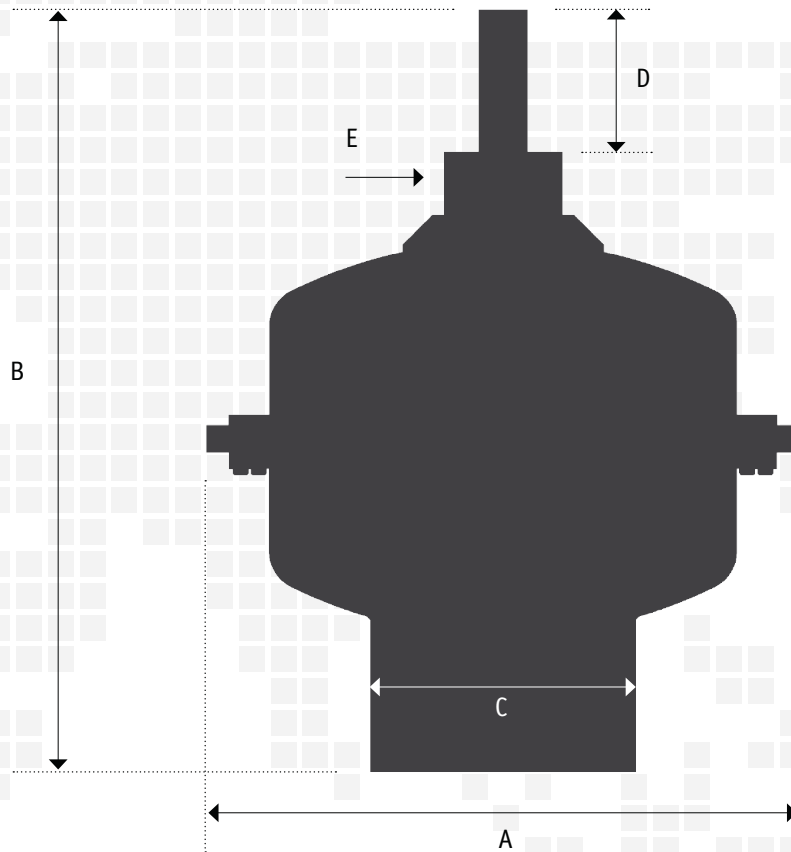

Actuator Model	Stroke ID	Size	Max Valve Stroke	A		B		C		D		E Thread	Swept Volume		Weight	
				in	mm	in	mm	in	mm	in	mm		in ³	cm ³	lb	kg
DX-10	-2	10"	2 1/16"	13.1	333	16.08	408	5.6	142	2.82	72	2.5" - 8 UNC 2A	158	2,587	67	30
DX-12	-2	12"	2 1/16"	15.1	384	19.05	484	6.75	171	3.24	82	3.0" - 8 UNC 2A	236	3,864	110	50
DX-12	-3	12"	3 1/8"	15.1	384	19.43	494	6.75	171	3.61	92	3.0" - 8 UNC 2A	300	5,000	108	49
DX-15	-2	15"	2 1/16"	18.2	462	20.7	526	7.9	201	2.92	74	3.0" - 8 UNC 2A	369	6,040	152	69
DX-15	-3	15"	3 1/8"	18.2	462	22.2	564	7.9	201	4.42	112	3.0" - 8 UNC 2A	446	7,303	153	69
DX-15	-4	15"	4 1/16"	18.2	462	22.85	580	7.9	201	5.07	129	3.0" - 8 UNC 2A	725	11,882	157	71
DX-18	-2	18"	2 1/16"	21.1	536	20.55	522	7.9	201	2.89	73	3.0" - 8 UNC 2A	530	8,677	188	85
DX-18	-3	18"	3 1/8"	21.1	536	21.73	552	7.9	201	4.07	103	3.0" - 8 UNC 2A	642	10,527	189	86
DX-18	-4	18"	4 1/16"	21.1	536	23.11	587	7.9	201	5.45	138	3.0" - 8 UNC 2A	1,042	17,070	194	88
DX-18	-6	18"	5 1/8"	21.1	536	27.11	689	7.9	201	7.45	189	3.0" - 8 UNC 2A	1,465	24,005	232	105
DX-20	-2	20"	2 1/16"	23.46	596	21.56	548	7.9	201	2.83	72	3.0" - 8 UNC 2A	659	10,799	262	119
DX-20	-3	20"	3 1/8"	23.46	596	22.73	577	7.9	201	4	102	3.0" - 8 UNC 2A	799	13,101	263	119
DX-20	-4	20"	4 1/16"	23.46	596	23.95	608	7.9	201	5.22	133	3.0" - 8 UNC 2A	1,234	20,227	268	122
DX-20	-6	20"	5 1/8"	23.46	596	27.95	710	7.9	201	7.22	183	3.0" - 8 UNC 2A	1,823	29,875	321	146
DX-20	-7	20"	7 1/16"	23.46	596	28.95	735	7.9	201	8.22	209	3.0" - 8 UNC 2A	2,093	34,298	385	175

TANDEM MODEL DX

Alternative Configurations



In situations where a single Model DX actuator will not generate sufficient force to open a valve, or when the availability of adequate control pressure might preclude the use of a single Model DX actuator, Omni can provide a “Tandem” configuration as depicted below.

The tandem configuration typically consists of a smaller diameter actuator stacked on top of a larger diameter actuator; however, it is also possible to stack two actuators of equal diameter on top of each other.

The force generated by the tandem actuator combination greatly exceeds that of a single actuator. This approach can be used to actuate most commercially available linear gate valves. Please consult Omni Valve for tandem actuator options.

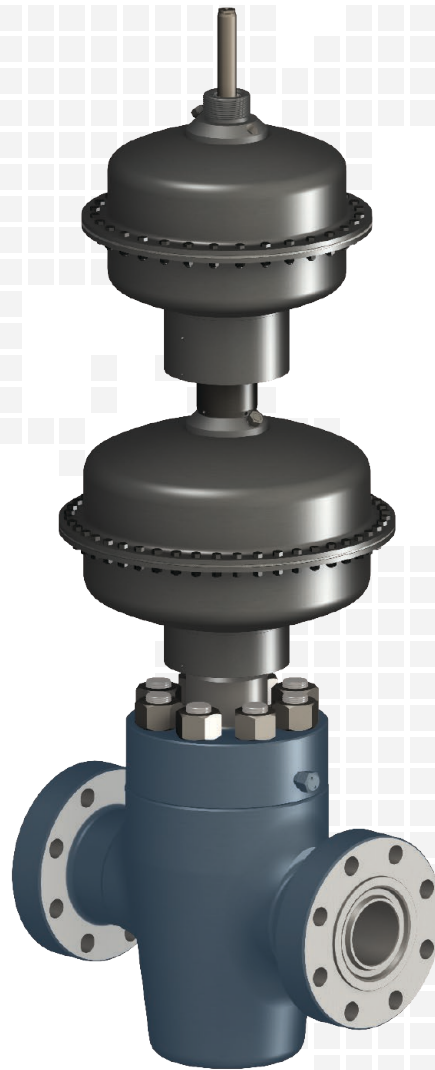

Actuator Model

Bore Size	Working Pressure	DX-1815		DX-1818		DX-2020	
		Equation	PSI	Equation	PSI	Equation	PSI
7-1/16"	5,000					.024 x wp+1.92 =	122
4-1/16"	10,000	.016 x wp + 1.92 =	160	.013 x wp+1.92 =	136	.011 x wp+1.92 =	110
5-1/8"	10,000					.014 x wp+1.92 =	144
3-1/16"	15,000	.011 x wp + 1.92 =	167	.009 x wp+1.92 =	137	.007 x wp+1.92 =	107
4-1/16"	15,000					.011 x wp+1.92 =	164

TANDEM MODEL DX

Internal Configuration & Redress Parts

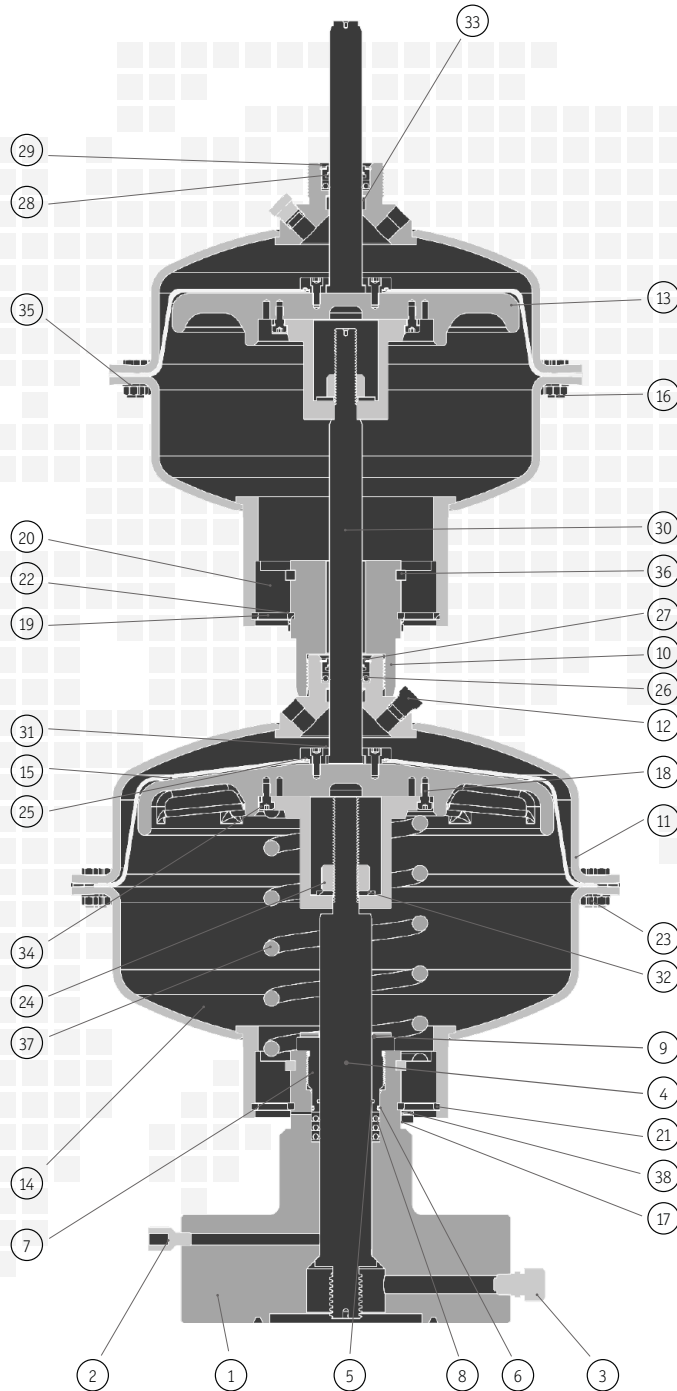

ITEM NO.	DESCRIPTION	QTY
1	Bonnet	1
2	Bonnet Vent Fitting	1
3	Body Grease Fitting	1
4	Operating Stem	1
5	Packing Retainer O-Ring	1 (BRK)
6	Packing Retainer O-Ring	1 (BRK)
7	Packing Retainer	1
8	Stem Seals	3 (BRK)
9	Drift Shims	3
10	Tandem Adapter	1
11	Upper Housing Assembly	2
12	Pressure Relief Valve (See Note 1)	2
13	Diaphragm Retainer Plate	2
14	Lower Housing Assembly	2
15	Diaphragm Assembly	2 (ARK)
16	Housing Bolts (See Note 2)	Varies (ARK)
17	Bonnet Clamp Ring Bolts	20 (AAK)
18	Spring Retainer Cup Bolts	4
19	Bonnet Clamp Ring Set	2 (AAK)
20	Bonnet Ring	2
21	Spring Tube Retaining Ring	2 (AAK)
22	Lower Bonnet Retaining Ring	2 (AAK)
23	Housing Nuts (See Note 2)	Varies (ARK)
24	Stem Nut	2 *
25	Upper Shaft Retainer O-Ring	2 (ARK)
26	Upper Shaft Seal	2 (ARK)
27	Shaft Seal Retainer Ring	2 (ARK)
28	Rod Wiper	2 (ARK)
29	Shaft Seal Retainer	2 ARK
30	Upper Shaft	2
31	Upper Shaft Retainer	2
32	Stem Washer	2
33	Wear Band	2 (ARK)
34	Spring Retainer Cup	2
35	Housing Lock Washer (See Note 2)	Varies (ARK)
36	Upper Bonnet Retaining Ring	2 (AAK)
37	Spring	1
38	Lock Washer	8

* Dependent upon valve size

(ARK = Actuator Redress Kit Item) (AAK = Actuator Attachment Kit Item) (BRK = Bonnet Redress Kit Item)

Note 1: Pressure relief valve is set at 170 psi. Valve will relieve any pressure above 170 psi inside the upper housing and then automatically reset.

Note 2: The number of housing bolts, washers and nuts depends on actuator model. DX-10 (24) / DX-12 (24) / DX-15 (32) / DX-18 (48) / DX-20 (60)

Note 3: The specific configuration of bonnet and operating stem is dependent on valve design. Omni Model DX actuators can be adapted to operate valves from any valve manufacturer.

MODEL PX

Piston Actuator



Available Sizes

Model	Size	Stroke
PX 09	9"	Up to 2 1/16" bore
PX 13	13"	Up to 3 1/8" bore
PX 15	15"	Up to 4 1/16" bore
PX 18	18"	Up to 7 1/16" bore
PX 20	20"	Up to 7 1/16" bore

Intro

Omni Model PX pneumatic piston actuators are designed to operate surface safety or shutdown valves on oil & gas wellhead, transmission, storage, manifold or other applications where fail-safe capability is required.

Model PX actuators can be used for land or off shore installations and are engineered to provide reliable service in a variety of operating conditions.

Omni can provide Model PX actuators already mounted on valves and ready to deploy, or as actuated bonnet assemblies ready to mount on valves from other manufacturers.

Additionally, Omni offers a full range of accessories including standard & fusible manual overrides, position indicators and fusible lock open devices.

Features

Flexibility

Model PX actuators can be adapted to operate valves from any manufacturer (interface information is required) and can be delivered with alternate materials of construction if required by field conditions.

Over-Pressure Protection

Model PX actuators come equipped with pressure relief devices to protect personnel and guard against damage to the actuator in case of an over pressure condition. The pressure relief device is easily inspected and is field-replaceable.

Orientation, Rotation & Ease of Piping

Model PX actuators have pressure inlet and outlet ports located at convenient locations on the upper housing assembly and can be rotated to facilitate proper piping orientation based on field conditions. Once proper orientation has been achieved, the actuator's lower bonnet retaining ring can be locked into place to prevent accidental rotation of the actuator while in service.

Backseat & Packing Integrity

Model PX actuators incorporate bonnet assemblies that have an integrated metal-to-metal backseat. A bonnet fitting can also be used to relieve any pressure that might be trapped between the backseat and stem packing after the backseat operation. A tattletale weep port is located above the packing to provide visual confirmation of stem seal integrity during operation. All Model PX ports can be used to pipe fugitive emissions to a containment vessel, if required.

Corrosion Protection

Model PX actuator housings are internally and externally coated to prevent corrosion due to environmental conditions. All internal components are either stainless steel or are coated to prevent corrosion due to any contamination that might be present in the control pressure source.

Maintenance

Model PX actuators are designed for ease of maintenance. All non-metallic seals and other parts are easily replaceable.

INTERNAL CONFIGURATION & Redress Kit Parts

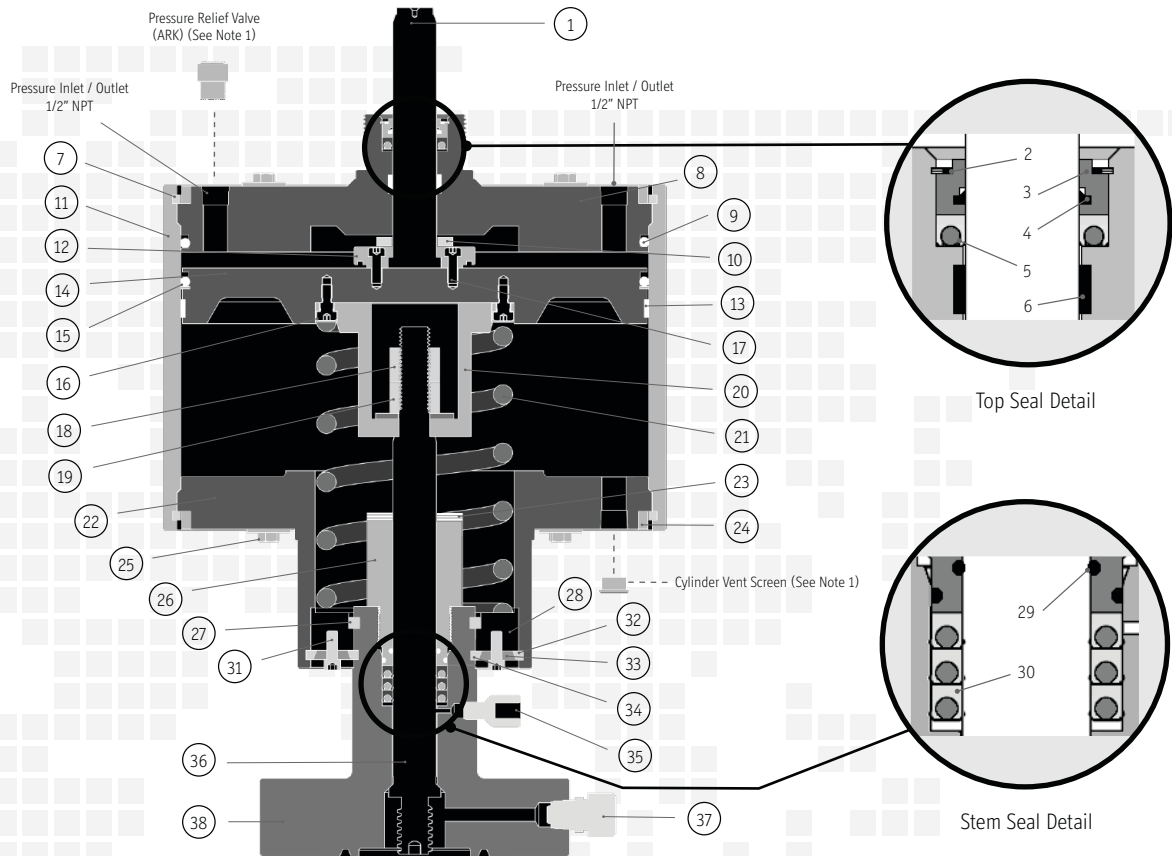

Internal Parts - Non Redress Kit Items

Component	Description	Qty
1	Upper Shaft	1
7	Cylinder Retainer Ring (1 Upper, 1 Lower)	2
8	Upper Plate Assembly	6
10	Piston Spacer Ring	1
11	Cylinder	1
12	Upper Shaft Retainer	1
14	Piston	1
16	Spring Retainer Cup Bolts	2
17	Upper Shaft Retainer Bolts	6
18	Stem Lock Nut	1
19	Stem Nut	1
20	Spring Cup	1
21	Spring	1
22	Lower Plate Assembly	1
23	Drift Shims	3
24	Cylinder Lock Ring (1 Upper, 1 Lower)	2
26	Packing Retainer	1
28	Bonnet Ring	1
35	Bonnet Vent Fitting	1
36	Operating Stem (See Note 2)	1
37	Bonnet Lube Fitting (See Note 2)	1
38	Bonnet (See Note 2)	1

ARK = Actuator Redress Kit Items

Component	Description	Qty
2	Shaft Seal Retainer Ring	1 (ARK)
3	Shaft Seal Retainer	1 (ARK)
4	Rod Wiper	1 (ARK)
5	Upper Shaft Seal	1 (ARK)
6	Wear Band	1 (ARK)
9	Cylinder O-Ring	1 (ARK)
13	Piston Wear Band	1 (ARK)
15	Piston O-Ring / Backup Ring (See Note 3)	1/1 (ARK)
25	Cylinder Retaining Bolts / Washers (4 Upper / 4 Lower)	8/8 (ARK)

AAK = Actuator Attachment Kit Items

Component	Description	Qty
27	Upper Bonnet Retaining Ring	2 (AAK)
31	Bonnet Clamp Ring Bolts	4 (AAK)
32	Spring Tube Retaining Ring	4 (AAK)
33	Bonnet Clamp Ring	2 (AAK)
34	Lower Bonnet Retaining Ring	2 (AAK)

BRK = Bonnet Redress Kit Items

Component	Description	Qty
29	Packing Retainer O-Ring	2 (BRK)
30	Stem Seals	3 (BRK)

Note 1: Pressure relief valve is set at 250 psi. Valve will relieve any pressure above 250 psi inside the cylinder and then automatically reset.

Note 2: Configuration of flange face is different for 5,000 psi bonnets.

Note 3: All Model PX Actuators EXCEPT the Model PX-09 have both a Piston O-Ring and a Backup Ring. The Model PX-09 does not have a Backup Ring.

CONTROL PRESSURE CHARTS

Model PX



Bore Size	Working Pressure	Actuator Model									
		PX-09		PX-13		PX-15		PX-18		PX-20	
		Equation	PSI	Equation	PSI	Equation	PSI	Equation	PSI	Equation	PSI
2 1/16"	2,000	0.027 x WP + 6 psi =	60	0.012 x WP + 4 psi =	27						
2 9/16"	2,000			0.016 x WP + 4 psi =	35	0.017 x WP + 3 psi =	37				
3 1/8"	2,000			0.022 x WP + 4 psi =	48	0.029 x WP + 3 psi =	50				
4 1/16"	2,000							0.018 x WP + 2 psi =	38	0.015 x WP + 2 psi =	32
5 1/8"	2,000							0.029 x WP + 4 psi =	62	0.024 x WP + 3 psi =	51
7 1/16"	2,000									0.042 x WP + 3 psi =	87
2 1/16"	3,000	0.027 x WP + 6 psi =	87	0.012 x WP + 4 psi =	39						
2 9/16"	3,000			0.016 x WP + 4 psi =	52	0.012 x WP + 3 psi =	39				
3 1/8"	3,000			0.022 x WP + 4 psi =	71	0.017 x WP + 3 psi =	54				
4 1/16"	3,000					0.025 x WP + 3 psi =	77	0.018 x WP + 2 psi =	57	0.015 x WP + 2 psi =	46
5 1/8"	3,000							0.029 x WP + 4 psi =	91	0.024 x WP + 3 psi =	74
7 1/16"	3,000									0.042 x WP + 3 psi =	128
2 1/16"	5,000	0.027 x WP + 6 psi =	141	0.012 x WP + 4 psi =	63						
2 9/16"	5,000			0.016 x WP + 4 psi =	83	0.012 x WP + 3 psi =	63				
3 1/8"	5,000			0.022 x WP + 4 psi =	115	0.017 x WP + 3 psi =	88				
4 1/16"	5,000			0.033 x WP + 4 psi =	167	0.025 x WP + 3 psi =	126	0.018 x WP + 2 psi =	94	0.015 x WP + 2 psi =	76
5 1/8"	5,000							0.029 x WP + 4 psi =	150	0.024 x WP + 3 psi =	121
7 1/16"	5,000									0.042 x WP + 3 psi =	211
1 13/16"	10,000			0.014 x WP + 4 psi =	142	0.010 x WP + 3 psi =	108	0.008 x WP + 2 psi =	80	0.006 x WP + 2 psi =	64
2 1/16"	10,000			0.015 x WP + 4 psi =	153	0.011 x WP + 3 psi =	116	0.008 x WP + 2 psi =	86	0.006 x WP + 2 psi =	69
2 9/16"	10,000			0.017 x WP + 4 psi =	172	0.013 x WP + 3 psi =	130	0.009 x WP + 2 psi =	97	0.008 x WP + 2 psi =	78
3 1/16"	10,000			0.024 x WP + 4 psi =	240	0.018 x WP + 3 psi =	182	0.013 x WP + 2 psi =	134	0.011 x WP + 2 psi =	109
4 1/16"	10,000							0.023 x WP + 2 psi =	232	0.019 x WP + 2 psi =	188
5 1/8"	10,000	Under most circumstances a single PX actuator will not be sufficient - please contact Omni for options									
7 1/16"	10,000										
1 13/16"	15,000			0.014 x WP + 4 psi =	211	0.010 x WP + 3 psi =	160	0.008 x WP + 2 psi =	119	0.006 x WP + 2 psi =	96
2 1/16"	15,000			0.015 x WP + 4 psi =	228	0.011 x WP + 3 psi =	172	0.008 x WP + 2 psi =	128	0.007 x WP + 2 psi =	104
2 9/16"	15,000					0.016 x WP + 3 psi =	237	0.012 x WP + 2 psi =	175	0.009 x WP + 2 psi =	142
3 1/16"	15,000							0.016 x WP + 2 psi =	241	0.013 x WP + 2 psi =	195
4 1/16"	15,000	Under most circumstances a single PX actuator will not be sufficient - please contact Omni for options									
5 1/8"	15,000										
7 1/16"	15,000										

Standard Actuator Specifications

Maximum Operating Pressure (See Note 1)	250 PSI	Pressure relief device on actuator is set at 250 PSI
API Material Class	AA / BB / CC	Not appropriate if control source contains H2S (is sour)
API Temperature Rating	P (-20 F to 180 F)	(-29 C to 82 C)

DIMENSIONAL DATA

Model PX

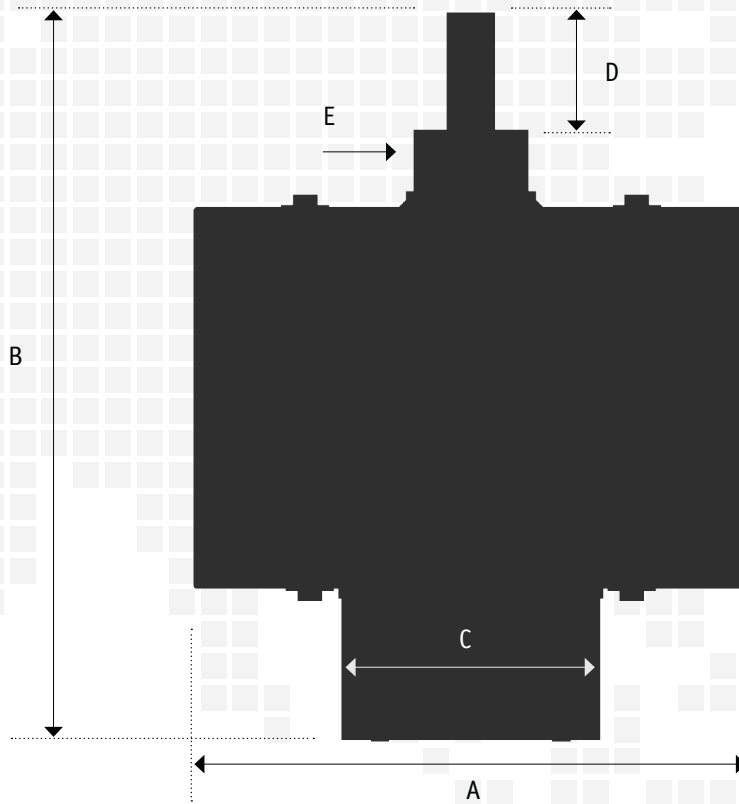

Actuator Data

Actuator Model	Stroke Id.	Size	Max Valve Stroke	A		B		C		D		E	Swept Volume		Weight	
				in	mm	in	mm	in	mm	in	mm	Thread	in3	cm3	lb	kg
PX-09	-2	9"	2 1/16"	9.99	254	16.14	410	5.6	142	2.69	68	2.5" - 8 UNC 2A	158	2,587	67	30
PX-13	-2	13"	2 1/16"	14.49	368	19.2	488	6.75	171	3.23	82	3.0" - 8 UNC 2A	365	5,977	263	119
PX-13	-3	13"	3 1/8"	14.49	368	20.17	512	6.75	171	4.19	106	3.0" - 8 UNC 2A	436	7,151	262	119
PX-15	-3	15"	3 1/8"	16.49	419	22.21	564	7.9	201	4.39	112	3.0" - 8 UNC 2A	712	11,673	381	173
PX-15	-4	15"	4 1/16"	16.49	419	22.86	581	7.9	201	5.04	128	3.0" - 8 UNC 2A	902	14,776	383	174
PX-18	-3	18"	3 1/8"	19.26	489	23.55	598	7.9	201	7.82	122	3.0" - 8 UNC 2A	960	15,736	540	245
PX-18	-4	18"	4 1/16"	19.26	489	23.99	609	7.9	201	5.26	134	3.0" - 8 UNC 2A	1,215	19,918	543	246
PX-18	-7	18"	7 1/16"	19.26	489	33.6	853	7.9	201	7.45	189	3.0" - 8 UNC 2A	1,958	32,093	638	289
PX-20	-3	20"	3 1/8"	21.55	547	33.2	843	11.2	284	4.82	122	3.0" - 8 UNC 2A	1,130	18,517	670	304
PX-20	-7	20"	7 1/16"	21.55	547	37.8	960	11.2	284	7.45	189	3.0" - 8 UNC 2A	2,421	39,673	825	374

MODEL PMX

Piston Actuator with Integrated Manual Override

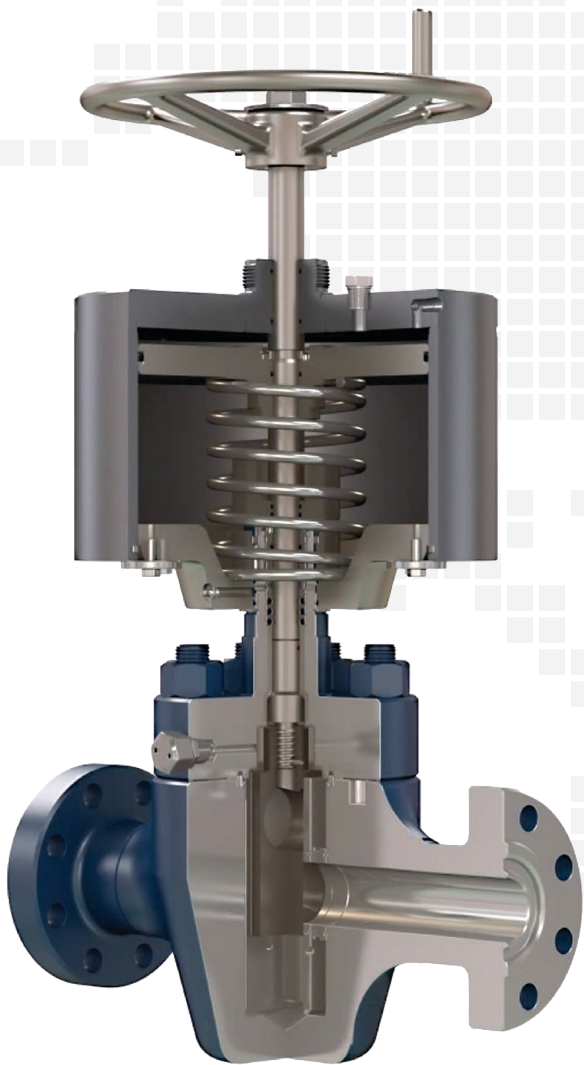

Available Sizes

Model	Size	Pressure (PSI)
PMX 13	2 1/16"	5,000
PMX 13	1 13/16"	10,000
PMX 13	2 1/16"	10,000

Intro

Omni Model PMX pneumatic piston actuators are designed to operate surface safety or shutdown valves on oil & gas wellhead, transmission, storage, manifold or other applications where fail-safe capability is required.

Model PMX actuators can be used for land or off shore installations and are engineered to provide reliable service in a variety of operating conditions.

Omni provides Model PMX actuators already mounted on valves and ready to deploy in 5,000 and 10,000 psi working pressures.

Features

Integrated Manual Override

Model PMX actuated valve assemblies are configured with an integrated manual override system to hold the valve open during well intervention or other servicing activities. The manual override cannot be separated from the actuator. This prevents loss or theft of the override mechanism while the valve is in service.

Over-Pressure Protection

Model PMX actuators come equipped with pressure relief devices to protect personnel and guard against damage to the actuator in case of an over-pressure condition. The pressure relief device is easily inspected and is field-replaceable.

Orientation, Rotation & Ease of Piping

Model PMX actuators have pressure inlet and outlet ports located at convenient locations on the upper housing assembly. The actuator can be rotated to facilitate proper piping orientation based on field conditions. Once proper orientation has been achieved, the actuator can be secured in position to prevent piping damage due to accidental rotation.

Integrated Backseat

Model PMX actuators incorporate bonnet assemblies that have an integrated metal-to-metal backseat that allows valve bore pressure to be isolated in the valve cavity while work is being performed on the actuator.

Corrosion Protection

Model PMX actuator housings are internally and externally coated to prevent corrosion due to environmental conditions. All internal components are either stainless steel or are coated to prevent corrosion due to any contamination that might be present in the pneumatic control pressure source.

Maintenance

Model PMX actuators are designed for ease of maintenance. All non-metallic seals and other parts are easily replaceable.

INTERNAL CONFIGURATION & Redress Kit Parts

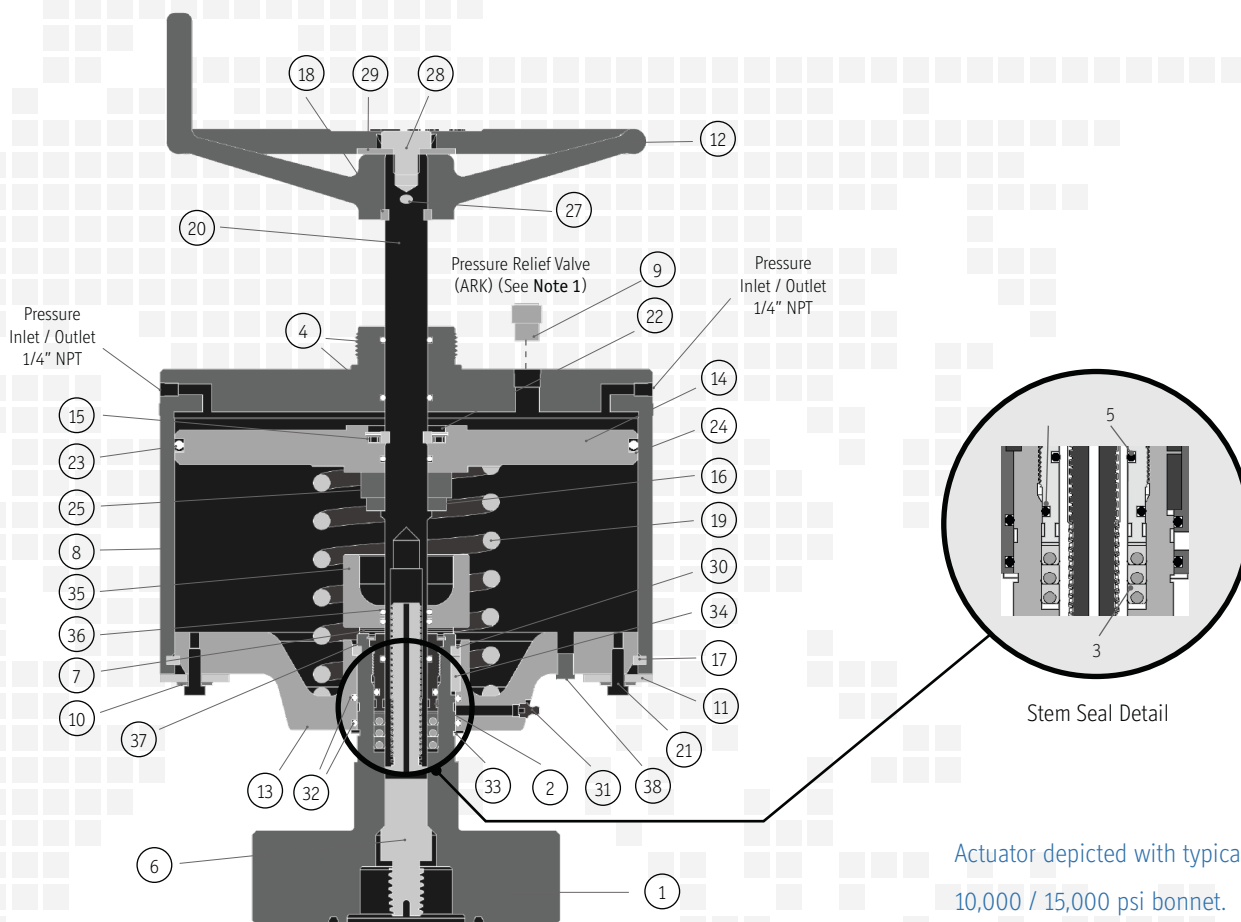

Actuator depicted with typical 10,000 / 15,000 psi bonnet.

Internal Parts - Non Redress Kit Items

Component	Description	Qty
1	Valve Bonnet (see Note 2)	1
2	Packing Retainer	1
6	Stem - Male	1
7	Drift Shim	3
8	Piston Housing	1
10	Cylinder Retaining Lock Washer	4
11	Cylinder Retaining Washer	4
12	Manual Override Hand Wheel	1
13	Lower Plate	1
14	Piston	1
15	Piston Retainer Bushing	1
16	Stem Shoulder Ring	1
17	Cylinder Snap Ring	1
18	Hand Wheel Split Ring	2
19	Spring	1
20	Upper Stem	1
21	Cylinder Retaining Bolt	4
22	Piston Retaining Ring / Fastener	1
25	Thrust Bearing	1
28	Hand Wheel Bolt	1
29	Hand Wheel Washer	1
30	Bonnet Retaining Ring	2
33	Lower Plate Retaining Ring / Fastener	1
34	Lower Plate Lock Pin	1
35	Down Stop	1

ARK = Actuator Redress Kit Items

Component	Description	Qty
4	Upper Stem Seal O-Ring (Buna N 70D 218)	3 (ARK)
9	Pressure Relief Fitting (250 psi)	1 (ARK)
23	Piston O-Ring (Buna N 70D 455)	1 (ARK)
24	Piston Backup Ring (Buna N 454)	1 (ARK)
27	Hand Wheel Pin (Bolt, Nut, Lock Washer)	1 (ARK)
31	Grease Fitting	1 (ARK)
32	Lower Plate O-Ring (Buna N 70D 233)	2 (ARK)
36	Down Stop Stem Seal O-Ring (Buna N 70D 218)	2 (ARK)
38	Breather Vent	1 (ARK)

BRK = Bonnet Redress Kit Items

Component	Description	Qty
3	Bonnet Packing	3 (BRK)
5	Inner Packing Retainer O-Ring (Buna N 70D 218)	1 (BRK)
26	Outer Packing Retainer O-Ring (Buna N 70D 223)	1 (BRK)
37	Packing Retainer Ring	1 (BRK)

Note 1: Pressure relief valve is set at 250 psi. Valve will relieve any pressure above 250 psi inside the cylinder and then automatically reset.

Note 2: Configuration of flange face is different for 5,000 psi bonnets.

CONTROL PRESSURE CHARTS

Model PMX



Control Pressure Equations

Bore Size	Working Pressure	Model PMX 13	
		Equation	PSI
2 1/16"	5,000	0.0136 x WP + 3 psi =	71
1 13/16"	10,000	0.0138 x WP + 3 psi =	141
2 1/16"	10,000	0.0149 x WP + 3 psi =	152

Standard Actuator Specifications

Maximum Operating Pressure (See Note 3)	250 PSI	Pressure relief device on actuator is set at 250 PSI
API Material Class (See Note 2)	AA / BB / CC	Alternate material classes available
API Temperature Rating	P (-20 F to 180 F)	(-29 C to 82 C)

Standard Bonnet Specifications

Available Sizes and Pressure Ratings	API 6A 2 1/16" - 5,000 psi	API 6A 1 13/16" - 10,000 psi
	API 6A 2 1/16" - 10,000 psi	
Available API Material Classes (See Note 2)	AA BB CC	For Non-Sour (Non-NACE) Service
	DD-0,5 DD-1,5 DD-NL	EE-0,5 EE-1,5 EE-NL FF-0,5 FF-1,5 FF-NL HH-0,5 HH-1,5 HH-NL
	FF-0,5 FF-1,5 FF-NL	
Available API Product Specification Level (PSL)	PSL-1, 2, or 3	
Available API Temperature Ratings (See Note 4)	L (-50 F) to X (350 F)	(-46 C) to (177 C)

Note 1: All specifications listed on this technical bulletin are subject to change without notice.

Note 2: If control source contains H₂S, please contact Omni for alternate materials of construction. Specific materials of construction for all material classes and temperature ratings can be changed upon customer request; however, Omni reserves the right to monogram Actuators and Bonnets with material class "ZZ" as per API requirements if those requested by the customer do not meet the current requirements of NACE MR 0175 / ISO 15156.

Note 3: Maximum Operating Pressure refers to the control pressure source.

Note 4: In cases where the bonnet carries a temperature rating above P (U or X for example), mating the bonnet to an actuator will not cause the actuator's temperature rating to be increased. In these cases, it is appropriate to consider the actuator and bonnet assembly to have a temperature rating equivalent to the lower rating of the bonnet or actuator.

DIMENSIONAL DATA

Model PMX

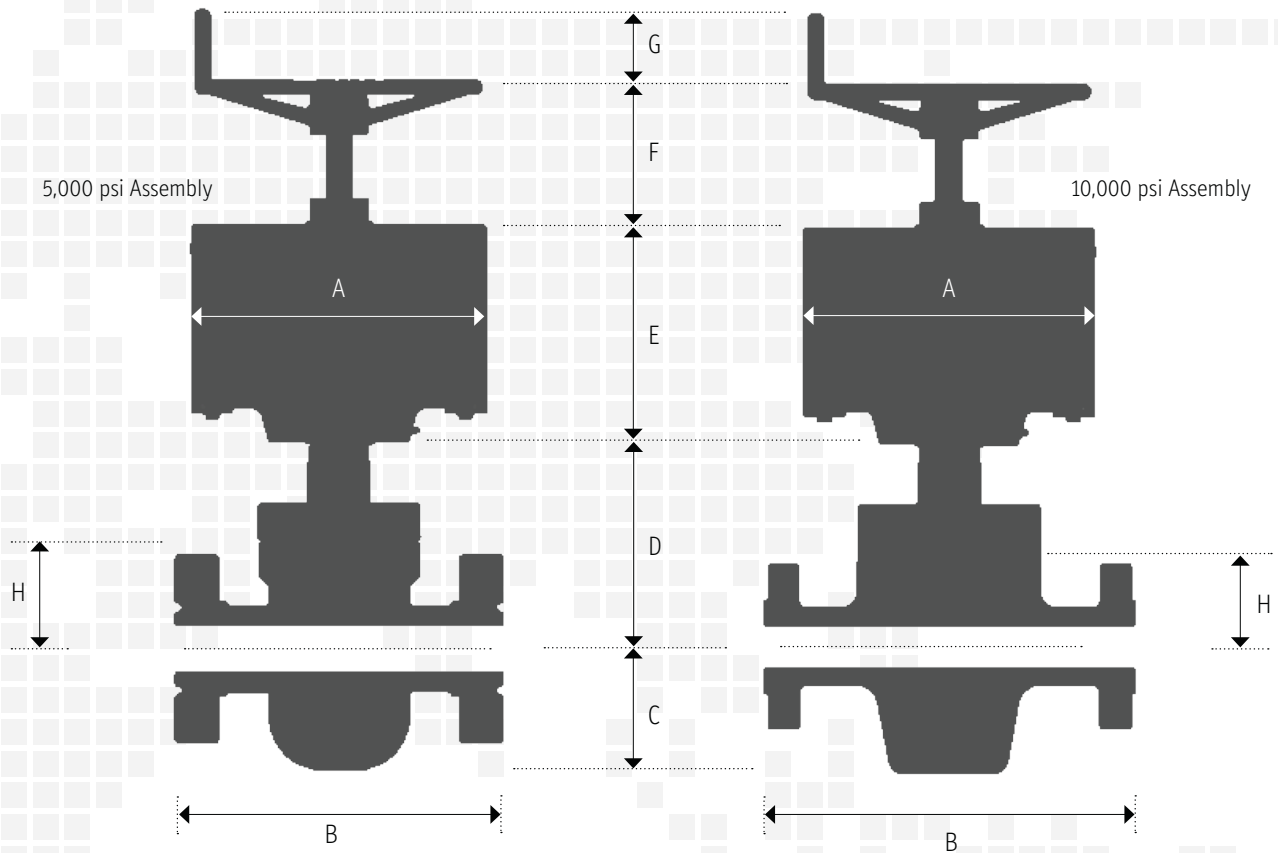

Sizing Chart

Valve Size	Working Pressure	A		B		C		D		E		F		G		H		Weight	
		in	mm	in	mm	in	mm	in	mm	in	mm	in	mm	in	mm	in	mm	lb	kg
2 1/16	5,000	14.38	365	14.62	371	5.06	128	9.07	230	10.49	266	4.65	118	3.39	86	4.84	123	366	166
1 13/16	10,000	14.38	365	18.25	464	5.69	145	8.83	224	10.49	266	4.99	127	3.39	86	3.88	99	421	191
2 1/16	10,000	14.38	365	20.50	521	5.69	145	9.56	243	10.49	266	4.65	118	3.39	86	3.88	99	452	205

MODEL HX

Fail Safe Actuator



Intro

Omni Model HX hydraulic actuators are designed to operate surface safety or shutdown valves on oil & gas wellhead, transmission, storage, manifold or other applications where fail-safe capability is required.

Model HX actuators can be used for land or off shore installations and are engineered to provide reliable service in a variety of operating conditions.

Omni can provide Model HX actuators already mounted on valves and ready to deploy, or as actuated bonnet assemblies ready to mount on valves from other manufacturers. Omni also offers a full range of accessories including standard & fusible manual overrides, position indicators and fusible lock open devices.

Features

Flexibility

Model HX actuators can be adapted to operate valves from any manufacturer (interface information is required) and can be delivered with alternate materials of construction if required by field conditions.

Over-Pressure Protection

Model HX actuators come equipped with pressure relief devices to protect personnel and guard against damage to the actuator in case of an over pressure condition. The pressure relief device is easily inspected and is field-replaceable.

Non-Pressurized Actuator Housing

Model HX actuators have outer housings that are structural and protective only – they are not under hydraulic pressure. This helps protect personnel and equipment in the event of damage to the outer housing.

Backseat & Packing Integrity

Model HX actuators incorporate bonnet assemblies that have an integrated metal-to-metal backseat. A bonnet fitting can also be used to relieve any pressure that might be trapped between the backseat and stem packing after the backseat operation. A tattletale weep port is located above the packing to provide visual confirmation of stem seal integrity during operation. All Model HX ports can be used to pipe fugitive emissions to a containment vessel, if required.

Corrosion Protection

Model HX actuator housings are internally and externally coated to prevent corrosion due to environmental conditions. All internal components are either stainless steel or are coated to prevent corrosion due to any contamination that might be present in the control pressure source.

Maintenance

Model HX actuators are designed for ease of maintenance. All non-metallic seals and other parts are easily replaceable. Omni stocks redress kits for all sizes of Model HX Actuators.

Orientation, Rotation & Ease of Piping

The orientation of the control pressure port can be rotated to any angle for ease of piping while the actuator is not pressurized.

Available Sizes

Model	Size	STROKE
HX 20	2 1/2"	Up to 2 9/16" bore
HX 30	3 1/2"	Up to 4 1/16" bore
HX 40	4 1/2"	Up to 4 1/16" bore
HX 60	6 1/2"	Up to 7 1/16" bore
HX 90	9"	Up to 7 1/16" bore
HX 110	11"	Up to 7 1/16" bore

INTERNAL CONFIGURATION & Redress Kit Parts

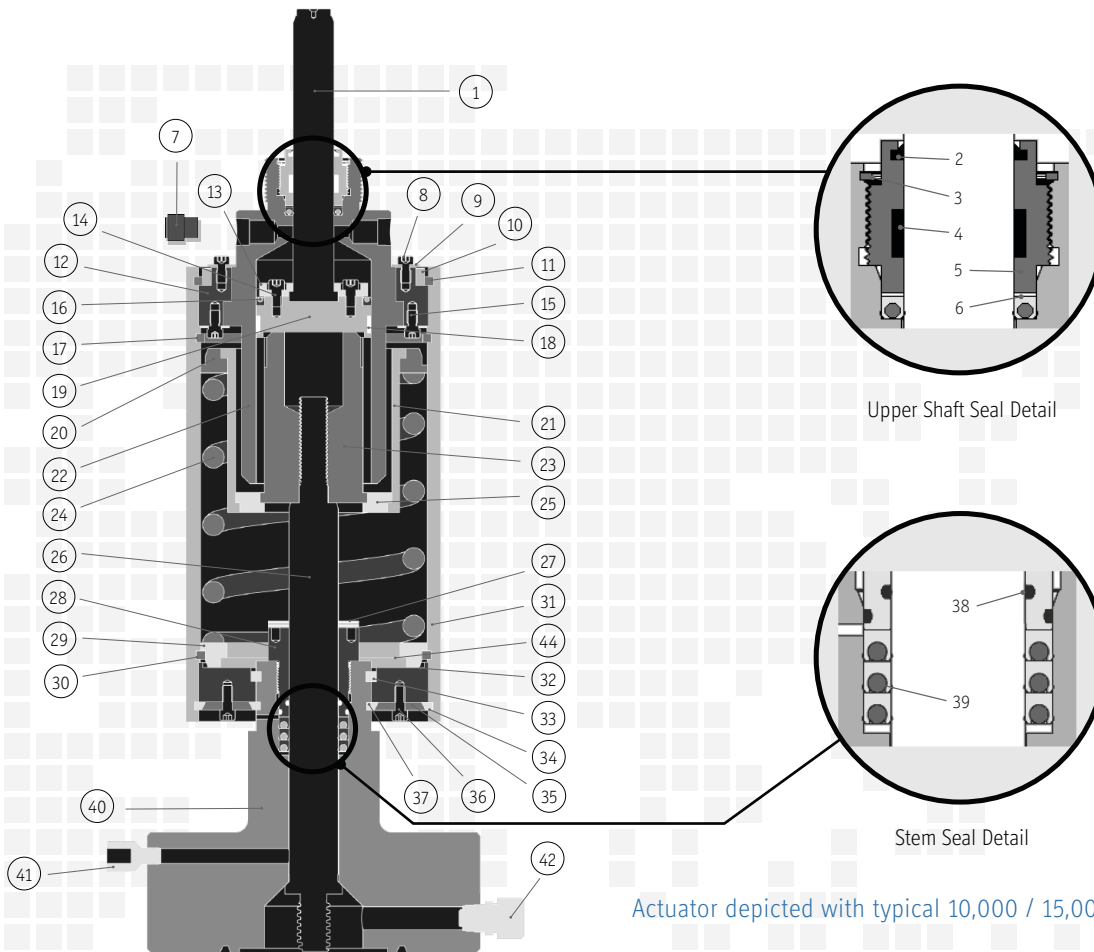

Actuator depicted with typical 10,000 / 15,000 psi bonnet

Internal Parts - Non Redress Kit Items

Component	Description	Qty
1	Upper Shaft	1
5	Upper Shaft Seal Retainer	1
8	Housing Bolts	4
9	Housing Washers	4
10	Housing Retainer Ring	1
11	Housing Snap Ring	1
12	Cylinder Adapter Ring	1
13	Upper Shaft Retainer Plate	1
14	Socket Head Cap Screw - Retainer (Note 3)	Varies
15	Socket Head Cap Screw - Adapter (Note 3)	Varies
17	Spring Retainer Snap Ring - Upper	1
19	Piston	1
20	Spring Retainer Plate - Upper	1
21	Spring Retainer Tube	1
22	Cylinder	1
23	Spring Adjustment Nut (Note 1)	1
24	Spring	1
25	Spring Retainer Plate - Lower	1
26	Operating Stem	1
27	Drift Shims	3
28	Packing Retainer	1
29	Spring Retainer Plate - Lower	1
30	Spring Retainer Snap Ring - Lower	1
31	Housing	1
32	Bonnet Ring	1
40	Valve Bonnet (See Note 2)	1
41	Bonnet Vent Fitting (Note 2)	1
42	Valve Lubrication Fitting (Note 2)	1

ARK = Actuator Redress Kit Items

Component	Description	Qty
2	Rod Wiper	1 (ARK)
3	Retainer Ring	1 (ARK)
4	Wear Band	1 (ARK)
6	Upper Shaft Seal	1 (ARK)
7	Burst Disc	1 (ARK)
16	Piston Seal	1 (ARK)
18	Piston Wear Band	1 (ARK)

AAK = Actuator Attachment Kit Items

Component	Description	Qty
33	Bonnet Retaining Ring - Upper	2 (AAK)
34	Spring Tube Retaining Ring - Lower	4 (AAK)
35	Bonnet Clamp Ring	2 (AAK)
36	Socket Head Cap Screw (Note 3)	Varies (AAK)
37	Bonnet Retaining Ring - Lower	2 (AAK)

BRK = Bonnet Redress Kit Items

Component	Description	Qty
38	Packing Retainer O-Ring	2 (BRK)
39	Stem Seal	3 (BRK)

Note 1: Actuators for some valve sizes have a counter-bore on the upper portion of the nut - example shows counter-bore. Some sizes have all-thread.

Note 2: The specific configuration of bonnet and operating stem is dependent on valve design. Omni Model HX actuators can be adapted to operate valves from any manufacturer. Location and configuration of bonnet fittings is also dependent on valve manufacturer's design. Example depicts standard Omni 10,000 psi bonnet design.

Note 3: Varies depending on valve size. Consult factory for exact quantity.

ACTUATOR CONTROL PRESSURES

Model HX



Bore Size	Working Pressure	Actuator Models														
		HX-20		HX-30		HX-40		HX-60		HX-90		HX-110				
		Equation	PSI	Equation	PSI	Equation	PSI	Equation	PSI	Equation	PSI	Equation	PSI			
2 1/16"	2,000	0.461 x WP + 109 psi=	1031	0.202 x WP + 60 psi=	464											
2 9/16"	2,000	0.612 x WP + 109 psi=	1333	0.268 x WP + 60 psi=	596	0.153 x WP + 102 psi=	408									
3 1/8"	2,000			0.378 x WP + 60 psi=	816	0.216 x WP + 102 psi=	534									
4 1/16"	2,000					0.315 x WP + 102 psi=	732									
5 1/8"	2,000							0.230 x WP + 63 psi=	523							
7 1/16"	2,000							0.405 x WP + 63 psi=	873							
2 1/16"	3,000	0.461 x WP + 109 psi=	1492	0.202 x WP + 60 psi=	666											
2 9/16"	3,000	0.612 x WP + 109 psi=	1945	0.268 x WP + 60 psi=	865	0.153 x WP + 102 psi=	563									
3 1/8"	3,000			0.378 x WP + 60 psi=	1193	0.216 x WP + 102 psi=	750									
4 1/16"	3,000					0.315 x WP + 102 psi=	1048	0.145 x WP + 63 psi=	497							
5 1/8"	3,000							0.230 x WP + 63 psi=	755							
7 1/16"	3,000							0.405 x WP + 63 psi=	1280							
2 1/16"	5,000	0.461 x WP + 109 psi=	2414	0.202 x WP + 60 psi=	1070											
2 9/16"	5,000	0.612 x WP + 109 psi=	3169	0.268 x WP + 60 psi=	1402	0.153 x WP + 102 psi=	870									
3 1/8"	5,000			0.378 x WP + 60 psi=	1949	0.216 x WP + 102 psi=	1183									
4 1/16"	5,000					0.315 x WP + 102 psi=	1678	0.145 x WP + 63 psi=	787							
5 1/8"	5,000							0.230 x WP + 63 psi=	1216							
7 1/16"	5,000							0.405 x WP + 63 psi=	2092	0.188 x WP + 29 psi=	969					
1 13/16"	10,000			0.234 x WP + 60 psi=	2398	0.133 x WP + 102 psi=	1440	0.061 x WP + 63 psi=	677							
2 1/16"	10,000			0.252 x WP + 60 psi=	2583	0.144 x WP + 102 psi=	1545	0.067 x WP + 63 psi=	725							
2 9/16"	10,000			0.284 x WP + 60 psi=	2905	0.162 x WP + 102 psi=	1729	0.075 x WP + 63 psi=	810							
3 1/16"	10,000					0.228 x WP + 102 psi=	2383	0.104 x WP + 63 psi=	1110							
4 1/16"	10,000							0.182 x WP + 63 psi=	1883							
5 1/8"	10,000							0.230 x WP + 63 psi=	2363	0.163 x WP + 29 psi=	1659					
7 1/16"	10,000									0.289 x WP + 29 psi=	2919	0.191 x WP + 21 psi=	1931			
1 13/16"	15,000			0.234 x WP + 60 psi=	3567	0.133 x WP + 102 psi=	2108	0.061 x WP + 63 psi=	984							
2 1/16"	15,000			0.252 x WP + 60 psi=	3845	0.144 x WP + 102 psi=	2267	0.067 x WP + 63 psi=	1057							
2 9/16"	15,000					0.199 x WP + 102 psi=	3086	0.091 x WP + 63 psi=	1433							
3 1/16"	15,000							0.126 x WP + 63 psi=	1953							
4 1/16"	15,000							0.182 x WP + 63 psi=	2793	0.094 x WP + 29 psi=	1439					
5 1/8"	15,000									0.163 x WP + 29 psi=	2474	0.108 x WP + 21 psi=	1641			
7 1/16"	15,000											0.191 x WP + 21 psi=	2886			

Standard Actuator Specifications

Maximum Operating Pressure	4,000 PSI	Pressure relief device on actuator is set at 4,000 PSI
API Material Class	AA / BB / CC	Not appropriate if control source contains H2S (is sour)
API Temperature Rating	P (-20 F to 180 F)	(-29 C to 82 C)

Note: The burst disc setting varies and is dependent on valve and actuator configuration

DIMENSIONAL DATA

Specifications

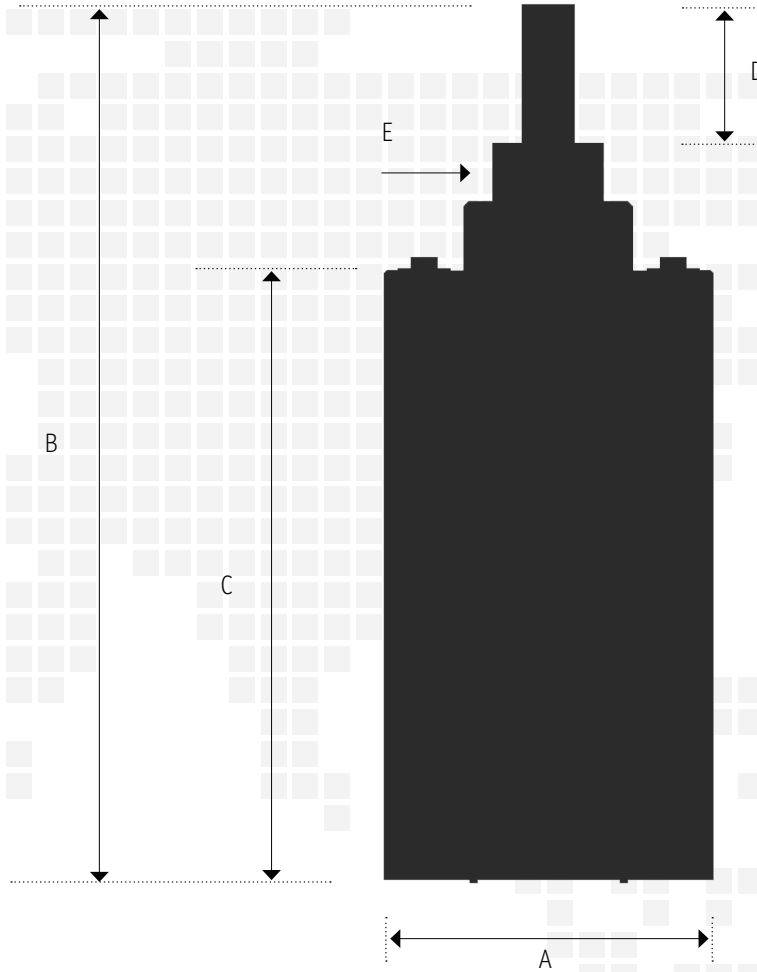

Actuator Data

Actuator Model	Stroke Identifier	Size	Max Valve Stroke	A		B		C		D		E Thread	Swept Volume		Weight	
				in	mm	in	mm	in	mm	in	mm		in ³	cm ³	lb	kg
HX-20	-2	2.5"	2 9/16"	5.3	135	17	432	9.5	241	3	76	2.5" - 8 UNC 2A	12	196	44	20
HX-30	-4	3.5"	4 1/16"	7.88	200	21.34	542	13.85	352	3.84	98	3.0" - 8 UNC 2A	40	655	131	59
HX-40	-4	4.5"	4 1/16"	9.98	253	29.52	749	20.25	514	5.82	148	3.0" - 8 UNC 2A	70	1,147	288	131
HX-60	-7	6.5"	7 1/16"	12.6	320	41.86	1063	29.18	741	8.82	224	3.0" - 8 UNC 2A	258	4,227	536	243
HX-90	-7	9"	7 1/16"	15.95	405	42.16	1071	29.61	752	8.73	222	3.0" - 8 UNC 2A	590	9,668	785	356
HX-110	-7	11"	7 1/16"	18.2	462	41.2	1046	27.25	692	8.1	206	3.0" - 8 UNC 2A	944	15,469	1,210	549

Actuator Closing Data

Actuator Model	Stroke ID	Size	Max Valve Stroke	Estimated Closing Time at Maximum Stroke In Seconds
HX-20	-2	2.5"	2 9/16"	2 to 5
HX-30	-4	3.5"	4 1/16"	6 to 9
HX-40	-4	4.5"	4 1/16"	7 to 10
HX-60	-7	6.5"	7 1/16"	10 to 13
HX-90	-7	9"	7 1/16"	12 to 15
HX-110	-7	11"	7 1/16"	15 to 18

Note: Actual closing times will depend on the configuration of system used to pipe fluid to and from the actuator as well as whether or not a quick exhaust valve is used.

Note: Values for models HX-20, HX-60, HX-90 & HX-110 are estimates and subject to change without notice.

MODEL HWX

Fail Safe Wire Cutting Actuator



Intro

Omni Model HWX hydraulic wire cutting actuators are designed to operate surface safety or shutdown valves on oil & gas wellhead, transmission, storage, manifold or other applications where fail-safe and wirecutting capabilities are required.

Model HWX actuators can be used for land or off shore installations and are engineered to provide reliable service in a variety of operating conditions.

Model HWX actuators are provided as actuated bonnet assemblies ready to mount on wire cutting valves from other manufacturers. Omni also offers a full range of accessories including standard & fusible manual overrides, position indicators and fusible lock open devices.

Features

Flexibility

Model HWX actuators can be adapted to operate valves from any manufacturer (interface information is required) and can be delivered with alternate materials of construction if required by field conditions.

Wire Cutting Capability

Model HWX actuators utilize a dual spring system designed to provide return force capable of shearing slickline, wireline, logging or stainless steel cable in typical wellhead applications with zero valve body pressure.

Over-Pressure Protection

Model HWX actuators come equipped with pressure relief devices to protect personnel and guard against damage to the actuator in case of an over pressure condition. The pressure relief device is easily inspected and is field-replaceable.

Structural (Unpressured) Housing

Model HWX actuators have outer housings that are structural and protective only – they are not under hydraulic pressure. This helps protect personnel and equipment in the event of damage to the outer housing.

Backseat & Packing Integrity

Model HWX actuators incorporate bonnet assemblies that have an integrated metal-to-metal backseat. A bonnet fitting can also be used to relieve any pressure that might be trapped between the backseat and stem packing after the backseat operation. A tattletale weep port is located above the packing to provide visual confirmation of stem seal integrity during operation. All Model HWX ports can be used to pipe fugitive emissions to a containment vessel, if required.

Corrosion Protection

Model HWX actuator housings are internally and externally coated to prevent corrosion due to environmental conditions. All internal components are either stainless steel or are coated to prevent corrosion due to any contamination that might be present in the control pressure source.

Maintenance

Model HWX actuators are designed for ease of maintenance. All non-metallic seals and other parts are easily replaceable. Omni stocks redress kits for all sizes of Model HWX Actuators.

Available Sizes

Model	Size	Stroke
HWX 40	4 1/2"	Up to 4 1/16" bore
HWX 60	6 1/2"	Up to 7 1/16" bore
HWX 90	9"	Up to 7 1/16" bore
HWX 110	11"	Up to 7 1/16" bore

INTERNAL CONFIGURATION & Redress Kit Parts

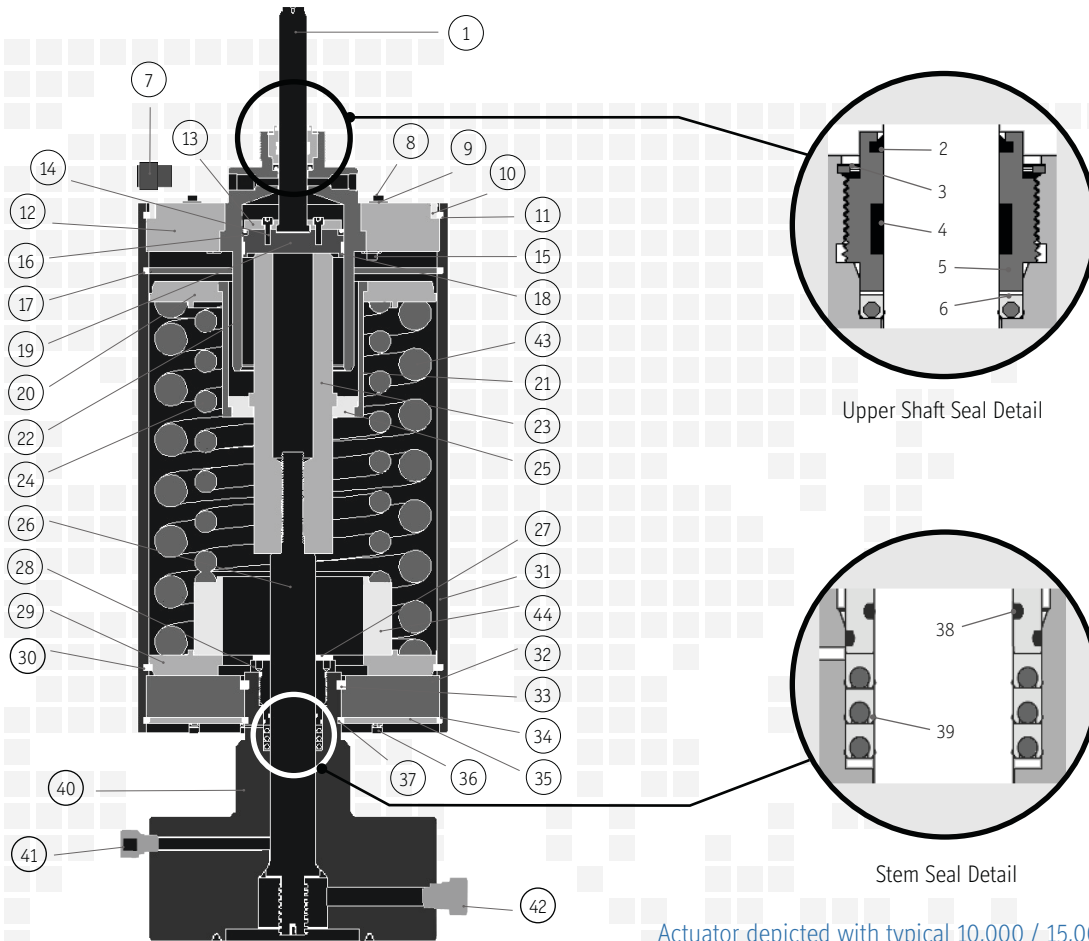

Actuator depicted with typical 10,000 / 15,000 psi bonnet

Internal Parts - Non Redress Kit Items

Component	Description	Qty
1	Upper Shaft	1
5	Upper Shaft Seal Retainer	1
8	Housing Bolts	4
9	Housing Washers	4
10	Housing Retainer Ring	1
11	Housing Snap Ring	1
12	Cylinder Adapter Ring	1
13	Upper Shaft Retainer Plate	1
14	Socket Head Cap Screw - Retainer (Note 3)	Varies
15	Socket Head Cap Screw - Adapter (Note 3)	Varies
17	Spring Retainer Snap Ring - Upper	1
19	Piston	1
20	Spring Retainer Plate - Upper	1
21	Spring Retainer Tube	1
22	Cylinder	1
23	Spring Adjustment Nut (Note 1)	1
24	Spring	1
25	Spring Retainer Plate - Lower	1
26	Operating Stem	1

Component	Description	Qty
27	Drift Shims	3
28	Packing Retainer	1
29	Spring Retainer Plate - Lower	1
30	Spring Retainer Snap Ring - Lower	1
31	Housing	1
32	Bonnet Ring	1
40	Valve Bonnet (Note 2)	1
41	Bonnet Vent Fitting (Note 2)	1
42	Valve Lubrication Fitting (Note 2)	1
43	Outer Spring	1
44	Spacer	1

BRK = Bonnet Redress Kit Items

Component	Description	Qty
38	Packing Retainer O-Ring	2 (BRK)
39	Stem Seal	3 (BRK)

ARK = Actuator Redress Kit Items

Component	Description	Qty
2	Rod Wiper	1 (ARK)
3	Shaft Seal Retainer Ring	1 (ARK)
4	Wear Band	1 (ARK)
6	Upper Shaft Seal	1 (ARK)
7	Burst Disc	1 (ARK)
16	Piston Seal	1 (ARK)
18	Piston Wear Band	1 (ARK)

AAK = Actuator Attachment Kit Items

Component	Description	Qty
33	Bonnet Retaining Ring - Upper	2 (AAK)
34	Spring Tube Retaining Ring - Lower	4 (AAK)
35	Bonnet Clamp Ring	2 (AAK)
36	Socket Head Cap Screw (Note 3)	Varies (AAK)
37	Bonnet Retaining Ring - Lower	2 (AAK)

Note 1: Actuators for some valve sizes have a counter-bore on the upper portion of the nut - example shows counter-bore. Some sizes have all-thread.

Note 2: The specific configuration of bonnet and operating stem is dependent on valve design. Omni Model HWX actuators can be adapted to operate valves from any from any valve manufacturer. Location and configuration of bonnet fittings is also dependent on valve manufacturer's design. Example depicts standard Omni 10,000 psi bonnet design.

Note 3: Varies depending on valve size. Consult factory for exact quantity.

ACTUATOR CONTROL PRESSURES

Model HWX



Actuator Models

Bore Size	Working Pressure	HWX-40		HWX-60		HWX-90		HWX-110	
		Equation	PSI	Equation	PSI	Equation	PSI	Equation	PSI
2 9/16"	2,000	0.153 x WP + 545 psi =	851						
3 1/8"	2,000	0.216 x WP + 545 psi =	977						
4 1/16"	2,000	0.315 x WP + 545 psi =	1175						
5 1/8"	2,000			0.230 x WP + 250 psi =	710				
7 1/16"	2,000			0.405 x WP + 250 psi =	1060				
2 9/16"	3,000	0.116 x WP + 545 psi =	892						
2 9/16"	3,000	0.153 x WP + 545 psi =	1004						
3 1/8"	3,000	0.216 x WP + 545 psi =	1193						
4 1/16"	3,000	0.315 x WP + 545 psi =	1490						
5 1/8"	3,000			0.230 x WP + 250 psi =	940				
7 1/16"	3,000			0.405 x WP + 250 psi =	1465				
2 9/16"	5,000	0.116 x WP + 545 psi =	1123						
2 9/16"	5,000	0.153 x WP + 545 psi =	1310						
3 1/8"	5,000	0.216 x WP + 545 psi =	1625						
4 1/16"	5,000	0.315 x WP + 545 psi =	2120						
5 1/8"	5,000			0.230 x WP + 250 psi =	1400				
7 1/16"	5,000			0.405 x WP + 250 psi =	2275	0.188 x WP + 115 psi =	1055		
1 13/16"	10,000	0.133 x WP + 545 psi =	1875						
2 1/16"	10,000	0.144 x WP + 545 psi =	1985						
2 9/16"	10,000	0.162 x WP + 545 psi =	2165						
3 1/8"	10,000	0.228 x WP + 545 psi =	2825	0.104 x WP + 250 psi =	1290				
4 1/16"	10,000			0.182 x WP + 250 psi =	2070				
5 1/8"	10,000			0.230 x WP + 250 psi =	2550	0.163 x WP + 115 psi =	1745		
7 1/16"	10,000					0.289 x WP + 115 psi =	3005	0.191 x WP + 86 psi =	1996
1 13/16"	15,000	0.133 x WP + 545 psi =	2540	0.061 x WP + 250 psi =	1165				
2 1/16"	15,000	0.144 x WP + 545 psi =	2705	0.067 x WP + 250 psi =	1255				
2-9/16"	15,000	0.199 x WP + 545 psi =	3530	0.091 x WP + 250 psi =	1615				
3 1/16"	15,000			0.126 x WP + 250 psi =	2140				
4 1/16"	15,000			0.182 x WP + 250 psi =	2980	0.094 x WP + 115 psi =	1525		
5 1/8"	15,000					0.163 x WP + 115 psi =	2560	0.108 x WP + 86 psi =	1706
7 1/16"	15,000							0.191 x WP + 86 psi =	2951

Standard Actuator Specifications

Maximum Operating Pressure	4,000 PSI	Pressure relief device on actuator is set at 4,000 PSI
API Material Class	AA / BB / CC	Not appropriate if control source contains H2S (is sour)
API Temperature Rating	P (-20 F to 180 F)	(-29 C to 82 C)
Wire Cutting Data	Standard Wireline, Slickline, 7/32" Logging or 3/16" Stainless Steel Cable	

Note: The burst disc setting varies and is dependent on valve and actuator configuration

DIMENSIONAL DATA

Specifications

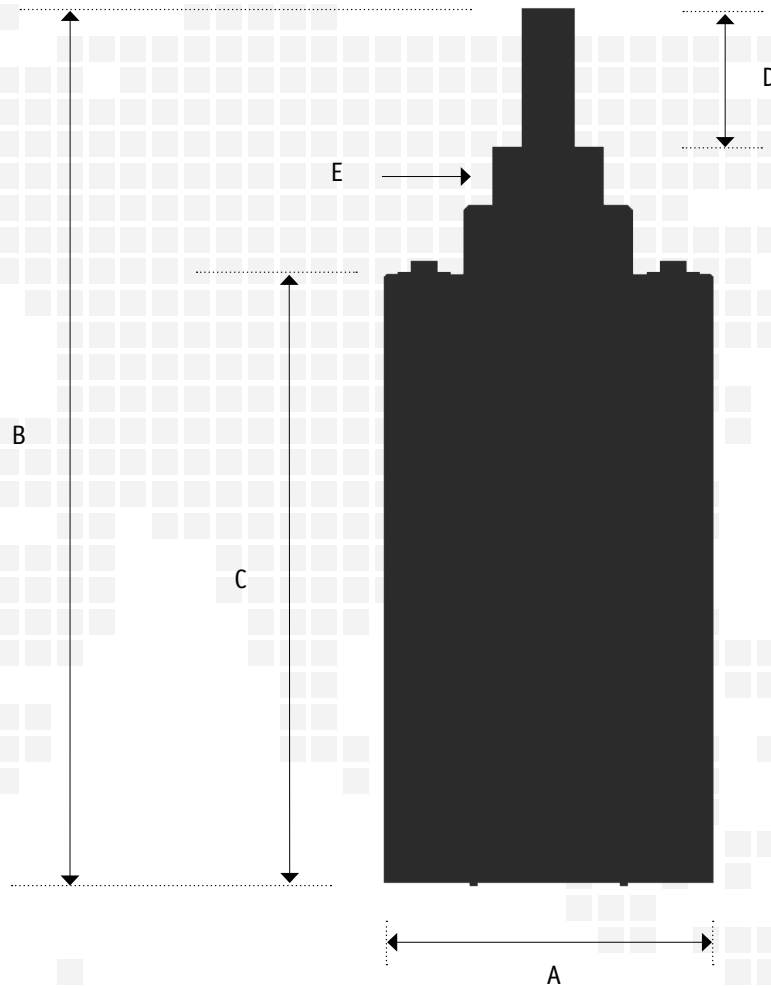

Actuator Data

Actuator Model	Stroke ID	Size	Max Valve Stroke	A		B		C		D		E Thread	Swept Volume		Weight	
				in	mm	in	mm	in	mm	in	mm		in (3)	cm (3)	lbs	kgs
HXW-40	-4	4.5"	4 1/16"	13.73	349	32.21	818	23.50	597	5.51	140	3.0" - 8UNC 2A	70	1,147	565	256
HXW-60	-7	6.5"	7 1/16"	16.50	419	36.00	914	25.00	635	8.10	206	3.0" - 8UNC 2A	258	4,228	842	382
HXW-90	-7	9"	7 1/16"	19.75	502	39.00	991	28.00	711	8.10	206	3.0" - 8UNC 2A	590	9,668	965	438
HXW-110	-7	11"	7 1/16"	22.00	559	42.00	1,067	31.00	787	8.10	206	3.0" - 8UNC 2A	944	15,469	1,289	585

Actuator Closing Data

Actuator Model	Stroke ID	Size	Max Valve Stroke	Estimated Closing Time at Maximum Stroke In Seconds
HXW-40	-4	4.5"	4 1/16"	7 to 10
HXW-60	-7	6.5"	7 1/16"	10 to 13
HXW-90	-7	9"	7 1/16"	12 to 15
HXW-110	-7	11"	7 1/16"	15 to 18

Note 1: Actual closing times will depend on the configuration of system used to pipe fluid to and from the actuator as well as whether or not a quick exhaust valve is used.

Note 2: Values for models HXW-40, HXW-60, HXW-90 & HXW-110 are estimates and subject to change without notice.

MODEL HDX

Double-Acting Piston Actuator

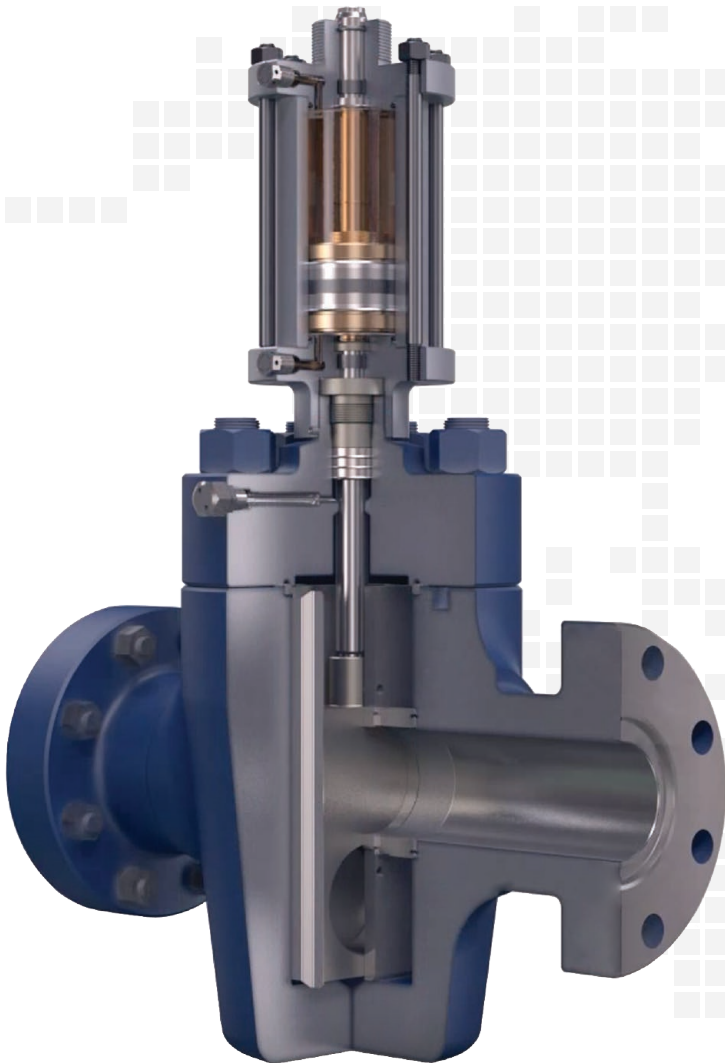

Intro

Omni Model HDX double-acting hydraulic actuators are designed to operate bi-directional sealing, through conduit gate valves in drilling, choke & kill, fracture, work over or other critical production applications.

Model HDX actuators are used to control the linear position of the valve gate and are used to either open or close the valve through application of hydraulic pressure to one of the actuator's designated pressure inlet ports.

Omni can provide complete valve assemblies with Model HDX actuators for immediate deployment or can adapt the actuators to valves from other valve manufacturers.

Features

Flexibility

The HDX actuators can be adapted to operate gate valves from any manufacturer and can be delivered with alternate materials of construction to meet various field conditions. The HDX actuators can be sized to meet most control pressure ranges.

Over-Pressure Protection

Model HDX actuators come equipped with a pressure relief device to protect personnel from harm and guard against damage to the actuator in case of an over pressure condition. The pressure relief device is easily inspected and is field replaceable.

Corrosion Protection

Model HDX actuators are internally and externally coated to prevent corrosion and wear due to environmental conditions. All internal components are either stainless steel or are coated to prevent corrosion due to any control pressure contamination.

Maintenance

Model HDX actuators are designed for ease of maintenance. All non-metallic seals and other parts are easily replaceable. Omni stocks redress kits for all sizes of Model HDX actuators.

Available Sizes

Model	Size	Stroke
HDX 40	4 1/2"	Up to 7 1/16" bore
HDX 60	6 1/2"	Up to 7 1/16" bore
HDX 90	9"	Up to 7 1/16" bore

INTERNAL CONFIGURATION & Redress Kit Parts



Internal Parts - Non Redress Kit Items

Component	Description	Qty
1	Bonnet	1
2	Stem	1
3	Packing Retainer Bushing	1
4	Grease Fitting (Not shown)	1
5	Cylinder	1
6	Cylinder Head Lower	1
7	Cylinder Head Upper	1
8	Stud	6 *
10	Piston	1
12	Piston Seal Retainer	2
16	Upper Shaft	1
17	Burst Disc	2
20	Hex Nut	6 *
21	Drift Shim	5
22	Upper Piston Stop	1
24	Socket Set Screw	2

* Dependent upon model

ARK = Actuator Redress Kit Items

Component	Description	Qty
9	Wear Bearing	2 (ARK)
11	Piston Polypak	2 (ARK)
13	Cylinder Head Polypak	2 (ARK)
14	O-ring	2 (ARK)
15	Backup-Ring	2 (ARK)
18	Rod Wiper	1 (ARK)
19	Cylinder Head Retainer Ring	2 (ARK)
23	Piston Retainer Ring	1 (ARK)
25	Socket Head Cap Screw	8 (ARK)
26	Piston Wear Bearing	1 (ARK)

Note: The specific configuration of bonnet and operating stem is dependent on valve design. Omni HDX actuators can be adapted to operate valves from any valve manufacturer.

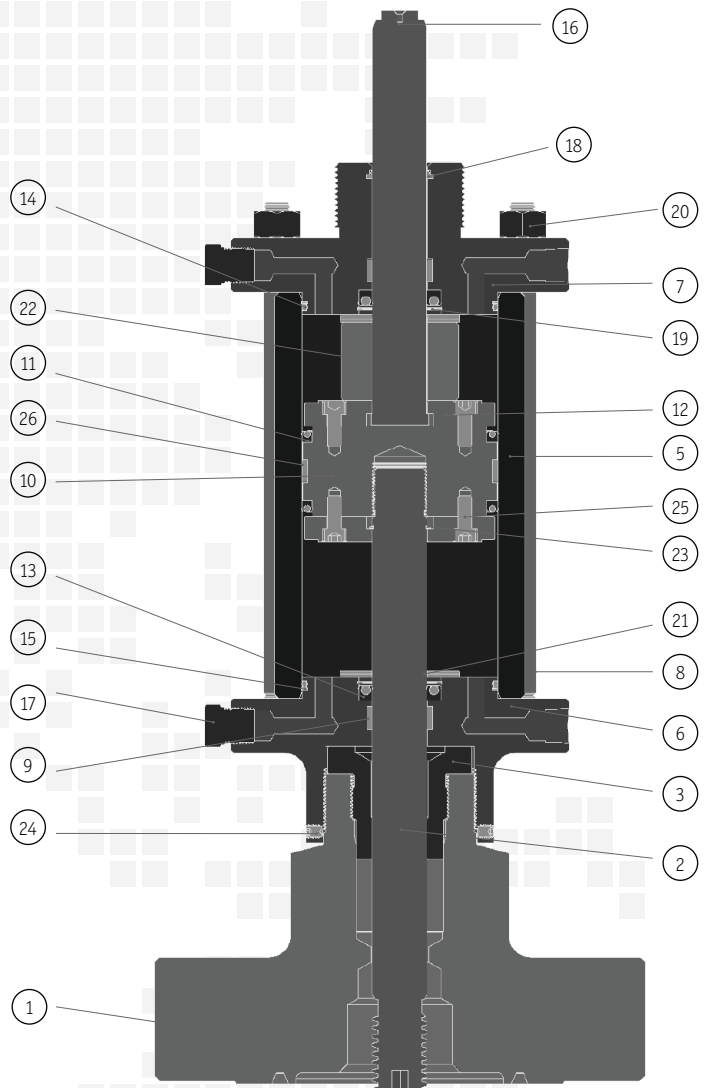

ACTUATOR CONTROL PRESSURES

Model HDX



Actuator Models

Bore Size	Working Pressure	HDX-40 Closing		HDX-40 Opening		HDX-60 Closing		HDX-60 Opening	
		Equation	PSI	Equation	PSI	Equation	PSI	Equation	PSI
2 1/16"	3,000	0.136 x WP =	409			0.053 x WP =	159		
2 9/16"	3,000	0.111 x WP =	333	0.028 x WP =	83				
3 1/8"	3,000	0.216 x WP =	648	-0.026 x WP =	-77				
4 1/16"	3,000	0.315 x WP =	946	-0.014 x WP =	-41				
5 1/8"	3,000					0.231 x WP =	692	-0.20 x WP =	-60
7 1/16"	3,000					0.405 x WP =	1217	-0.045 x WP =	-135
2 1/16"	5,000	0.136 x WP =	681			0.053 x WP =	2640		
2 9/16"	5,000	0.111 x WP =	554	0.028 x WP =	139				
3 1/8"	5,000	0.216 x WP =	1080	-0.026 x WP =	-128				
4 1/16"	5,000	0.315 x WP =	1576	-0.014 x WP =	-68				
5 1/8"	5,000					0.231 x WP =	1153	-0.020 x WP =	-100
7 1/16"	5,000					0.405 x WP =	2029	-0.045 x WP =	-224
1 13/16"	10,000	0.104 x WP =	1036	-0.003 x WP =	-33				
2 1/16"	10,000	0.114 x WP =	1142	0.007 x WP =	70				
2 9/16"	10,000	0.133 x WP =	1326	0.025 x WP =	248				
3 1/16"	10,000	0.228 x WP =	2281	-0.013 x WP =	-132	0.105 x WP =	1048	-0.006 x WP =	-59
4 1/16"	10,000	0.226 x WP =	2662	0.098 x WP =	990	0.122 x WP =	1223	0.045 x WP =	455
1 13/16"	15,000	0.104 x WP =	1555	-0.003 x WP =	-49				
2 1/16"	15,000	0.114 x WP =	1713	0.007 x WP =	105				
2 9/16"	15,000	0.181 x WP =	2721	0.014 x WP =	212	0.083 x WP =	1250	0.007 x WP =	98
3 1/16"	15,000					0.116 x WP =	1746	0.006 x WP =	89

Standard Actuator Specifications

Maximum Operating Pressure (See Note 1)	3,000 PSI	Pressure relief device on actuator is set at 3,000 PSI
API Material Class	AA / BB / CC	Not appropriate if control source contains H2S (is sour)
API Temperature Rating	P (-20 F to 180 F)	(-29 C to 82 C)

Note: The burst disc setting varies and is dependent on valve and actuator configuration

DIMENSIONAL DATA

Model HDX

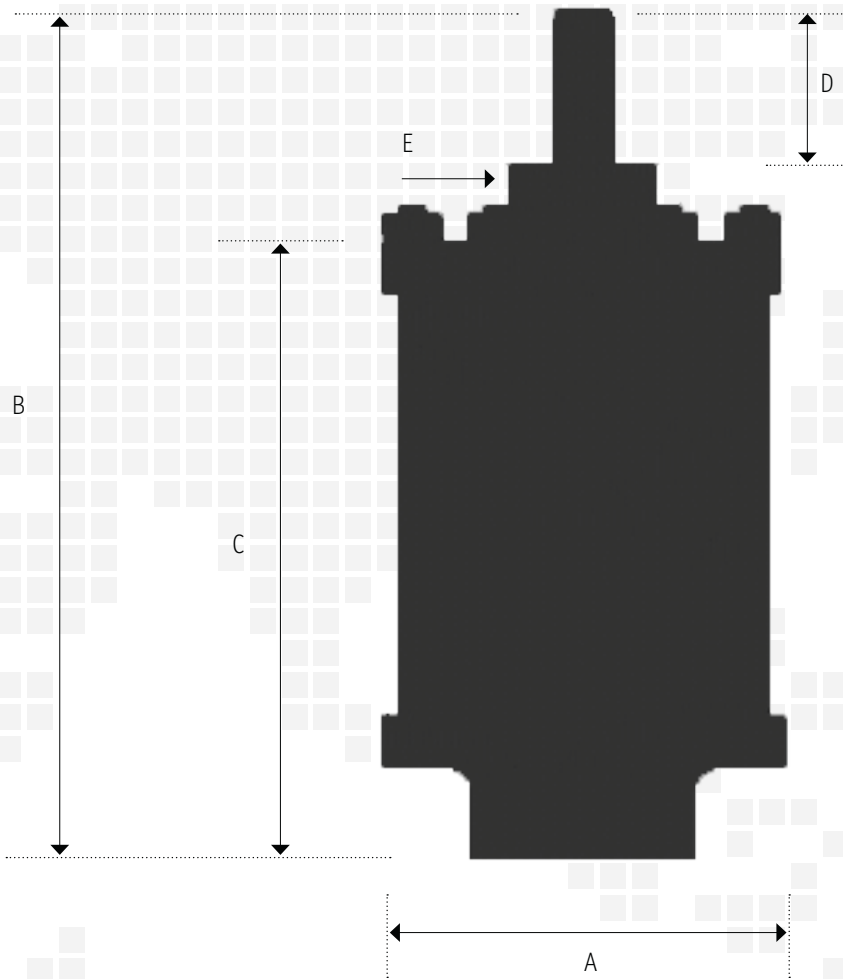

Actuator Data

Actuator Model	Stroke ID	Size	Max Valve Stroke	A		B		C		D		E Thread	Swept Volume		Weight	
				in	mm	in	mm	in	mm	in	mm		in (3)	cm (3)	lbs	kgs
HDX-40	-7	4.5"	7 1/16	7.75	197	19.07	484	13.86	352	3.48	88	3.0" - 8UNC 2A	80	1,303	91	41
HDX-60	-7	6.5"	7 1/16	9.75	248	24.07	611	17.86	454	8.10	206	3.0" - 8UNC 2A	258	4227	145	66
HDX-90	-7	9"	7 1/16	12.75	324	24.07	611	17.86	454	8.10	206	3.0" - 8UNC 2A	590	9668	218	99

BONNET SPECIFICATIONS

Pneumatic & Hydraulic Models



Bonnet dimensions provided are for Omni standard actuated bonnets. Dimensions for other manufacturers' bonnets could vary from those provided. In cases where Omni will provide actuators on valves provided by other manufacturers, Omni will supply complete dimensional drawings as part of the documentation package associated with the order.

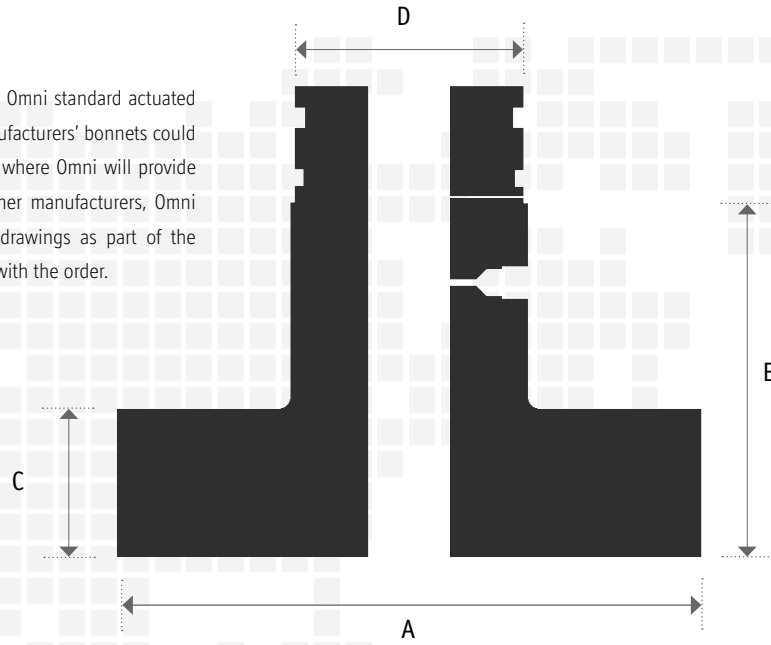

Bonnet Data

Valve Size	Working Pressure	A		B		C		D		Weight		Valve Size	Working Pressure	A		B		C		D		Weight	
		in	mm	in	mm	in	mm	in	mm	lb	kg			in	mm	in	mm	in	mm	in	mm	lb	kg
2 1/16"	2,000	6.38	161	4.45	114	1.2	30	3	76	17	7	2 13/16"	10,000	8.94	227	5.48	139	2.3	58	3.5	89	41	19
2 9/16"	2,000	7.28	184	4.96	125	1.4	36	3.5	89	30	14	2 1/16"	10,000	9	229	5.49	139	3	76	3.5	89	50	23
3 1/8"	2,000	8.5	215	5.13	130	2	51	3.5	89	36	16	2 9/16"	10,000	9.38	238	6.23	158	3.2	81	3.5	89	59	27
4 1/16"	2,000	11	279	5.44	138	2.14	54	4.25	108	70	32	3 1/16"	10,000	10.12	257	7.2	183	3.72	94	3.5	89	75	34
5 1/8"	2,000	13.07	331	6.54	166	2.68	68	5.2	132	99	44	4 1/16"	10,000	12.69	322	7.5	191	4.19	106	4.25	108	137	62
7 1/16"	2,000	15.53	394	7.2	183	3	76	7.2	183	204	92	5 1/16"	10,000	15	381	8	203	5.5	139	9	228	190	86
3 1/8"	3,000	9.03	229	4.23	107	1.58	40	3	76	41	19	7 1/16"	10,000	18	457	10	254	5.75	146	10.1	257	235	106
4 1/16"	3,000	11.9	302	5.31	135	2.14	54	4.25	108	75	14	1 13/16"	15,000	9.53	242	6.21	158	3.23	82	3.5	89	61	28
5 1/8"	3,000	13.07	331	6.54	166	2.68	68	5.2	132	106	48	2 1/16"	15,000	9.53	242	6.43	163	3.29	84	3.5	89	61	28
7 1/16"	3,000	15.53	394	7.2	183	3	76	7.2	183	210	95	2 9/16"	15,000	11.25	286	7.23	184	3.75	95	3.5	89	95	43
2 1/16"	3/5,000	7.16	182	4.23	107	1.58	40	3	76	19	8	3 1/16"	15,000	13.38	340	8.41	214	4.13	105	3.5	89	153	69
2 9/16"	3/5,000	7.8	198	5.31	135	2.14	54	3.5	89	30	14	4 1/16"	15,000	13.75	349	9	228	5	127	6.5	165	160	72
3 1/8"	5,000	9.03	229	5.48	139	2.43	62	3.5	89	41	19	5 1/8"	15,000	16.5	419	8	203	6.1	155	9	228	220	99
4 1/16"	5,000	11.9	302	5.5	140	2.59	66	4.25	108	80	36	7 1/16"	15,000	19.8	503	10	254	6.75	171	10.1	257	253	114
5 1/8"	5,000	13.07	331	6.88	174	2.68	68	5.2	132	109	49												
7 1/16"	5,000	15.53	394	7.2	183	3	76	7.2	183	210	95												

Standard Bonnet Specifications

Adaptable to Following Valve Brands	Omni Actuators can be adapted to fit valves from any manufacturer that can supply accurate valve interface information.	
Available Sizes (See Note 1)	API 6A 1 13/16" to 7 1/16"	API 6D / ANSI 2" to 10"
Available Pressure Ratings	API 6A 2,000 to 15,000 PSI	API 6D / ANSI Class 150 to 2500
Available API Material Classes (See Note 2)	AA BB CC	For Non-Sour (Non-NACE) Service
	DD-0,5 DD-1,5 DD-NL	EE-0,5 EE-1,5 EE-NL FF-0,5 FF-1,5 FF-NL HH-0,5 HH-1,5 HH-NL
Available API Product Specification Level (PSL)	PSL-1, 2, or 3	
Available API Temperature Ratings (See Note 3)	L (-50 F) to X (350 F)	(-46 C) to (177 C)

Note 1: Omni will develop actuated solutions for other valve sizes upon request.

Note 2: Specific materials of construction for all material classes and temperature ratings can be changed upon customer request; however, Omni reserves the right to monogram Actuators and Bonnets with material class "ZZ" as per API requirements if the materials of construction requested by the customer do not meet the current requirements of NACE MR 0175 / ISO 15156.

Note 3: In cases where the bonnet carries a temperature rating above P (U or X for example), mating the bonnet to an actuator will not cause the actuator's temperature rating to be increased. In these cases, it is appropriate to consider the actuator and bonnet assembly to have a temperature rating equivalent to the lower rating of the bonnet or actuator.

ACCESSORIES

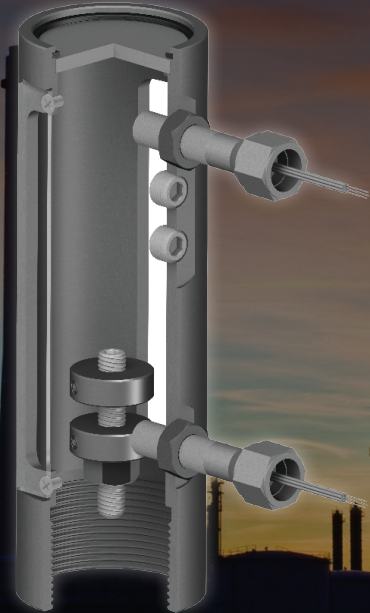
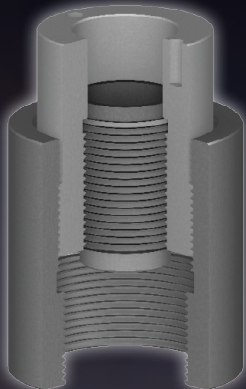

MANUAL OVERRIDE

For Pneumatic or Hydraulic Actuator Models

The Omni manual override is designed to mechanically hold open a reverse acting gate valve when well servicing, logging, testing or other intervention is required.

The Omni manual override can be installed on any Omni pneumatic or hydraulic actuator. The thrust bearing located at the end of the override stem reduces friction caused by high torque requirements and prevents damage to the actuator top shaft. A milled slot in the manual override housing allows the user to monitor the position of the override stem and determine the position of the gate valve.

All components of Omni manual overrides are stainless steel or coated carbon steel to ensure operability in severe operating conditions and are available for gate valves with bore sizes from 1 ¹³/₁₆" to 7 ¹/₁₆".

Parts List

Component	Description	Qty
1	Handwheel	1
2	Hex Nut	1
3	Washer	1
4	Stem	1
5	Housing	1
6	Thrust Bearing	1
7	Retainer Plate	1
8	Socket Head Cap Screw	1

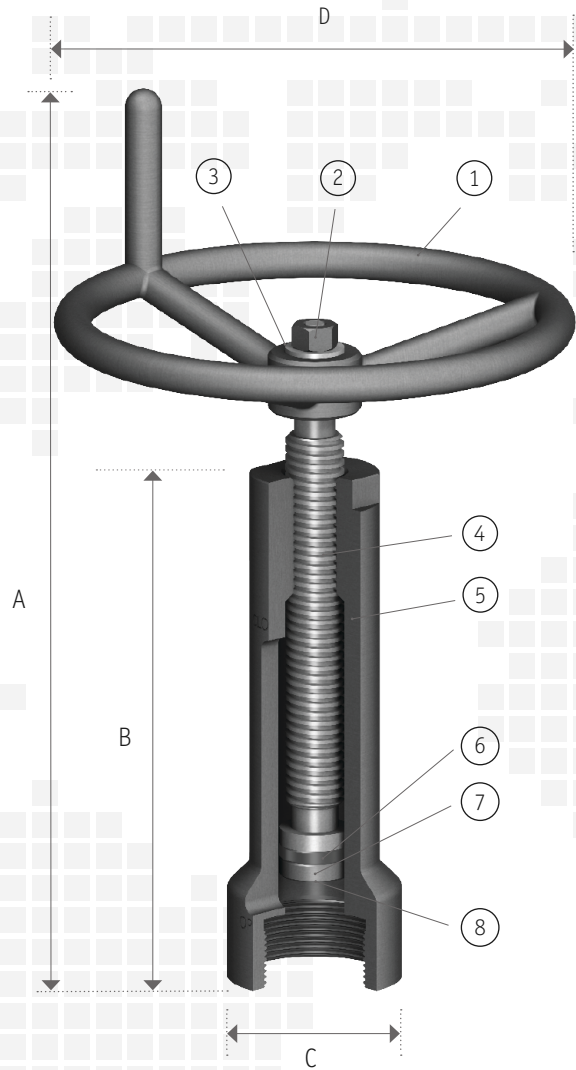

Dimensions

	A		B		C		D		Weight	
	in	mm	in	mm	in	mm	in	mm	lbs	kg
2.50 – 8UN-2B THD	14.67	373	8	203	3.13	80	11	279	17	8
3.00 – 8UN-2B THD	17.67	449	11	279	3.70	94	11	279	24	11
3.00 – 8UN-2B THD	22.77	577	15	381	3.50	89	16	406	35	16

FUSIBLE MANUAL OVERRIDE

For Pneumatic or Hydraulic Actuator Models



The Omni fusible manual override is designed to mechanically hold open a reverse acting gate valve when well servicing, logging, testing or other intervention is required. It contains a fusible element that is designed to melt under extreme heat. This allows the actuator to close the valve in the event of a fire or other high-heat emergency.

The Omni fusible manual override can be installed on any Omni pneumatic or hydraulic actuator. The thrust bearing located at the end of the override stem reduces friction caused by high torque requirements and prevents damage to the actuator top shaft. A milled slot in the manual override housing allows the user to monitor the position of the override stem and determine the position of the gate valve.

All non-fusible components of Omni fusible manual overrides are stainless steel or coated carbon steel to ensure operability in severe operating conditions and are available for gate valves with bore sizes from 1 ¹³/₁₆" to 7 ¹/₁₆".

Parts List

Component	Description	Qty
1	Handwheel	1
2	Hex Nut	1
3	Washer	1
4	Fusible Element	1
5	Stem	1
6	Retainer Plate	1
7	Retainer Ring	1
8	Bearing	1
9	Socket Head Cap Screw	1
10	Housing	1

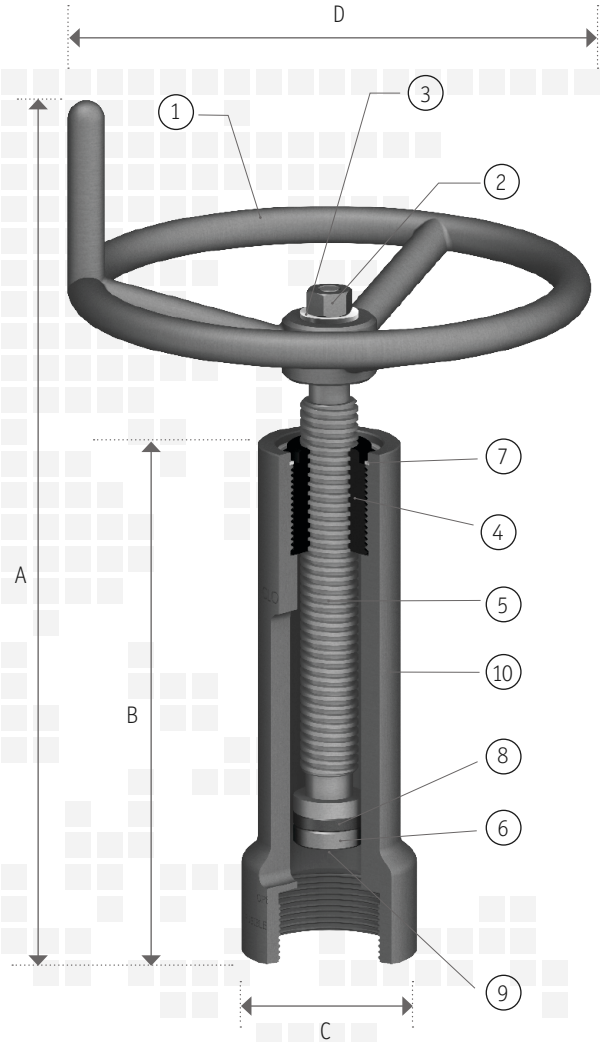

Dimensions

	A		B		C		D		Weight	
	in	mm	in	mm	in	mm	in	mm	lbs	kg
2.50 – 8UN-2B THD	14.67	373	8	203	3.13	80	11	279	19	9
3.00 – 8UN-2B THD	17.67	449	11	279	3.70	94	11	279	24	11
3.00 – 8UN-2B THD	22.77	577	14.5	368	3.50	89	16	406	35	16

SHIPPING CAP

For Pneumatic or Hydraulic Actuator Models

The Omni shipping cap is designed to mechanically hold the valve in the partially open position for the purpose of storage and shipping. The cap also serves to protect the upper indicator shaft and upper adapter from damage.

The Omni shipping cap can be installed on all Omni safety actuators.

The shipping cap should only be used during storage and shipment. It should never be installed on a valve during testing or while in service. The valve body should never be pressurized while the shipping cap is installed.

The construction material is low carbon steel. The shipping cap has been coated to prevent corrosion during storage and shipment.

- CAUTION:**
- Do not remove the shipping cap from an Omni actuator without an application of minimum operating pressure.
 - Failure to perform this sequential operation could result in injury to personnel.
 - It is not recommended to use the manual lock open device when hydrostatically testing API 6A gate valves and actuators.

Note: For wire cutting applications it is recommended that the Omni Fusible Manual Override be furnished.

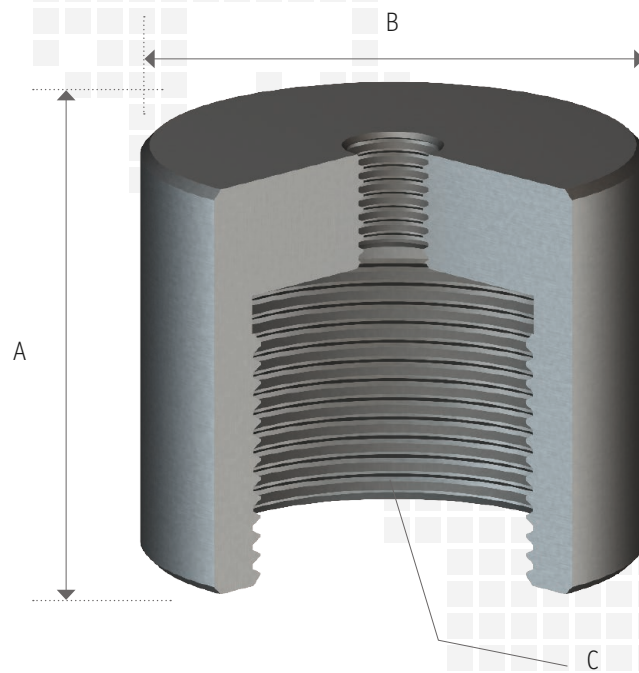

Dimensions

	A		B		C		Weight	
	in	mm	in	mm	in	mm	lbs	kg
2.50 – 8UN-2B THD	2.65	67	3.20	81	2.50	63	3	1
3.00 – 8UN-2B THD	3.00	76	3.70	94	3.00	76	4	2

FUSIBLE LOCK OPEN CAP

For Pneumatic or Hydraulic Actuator Models



The Omni fusible lock open cap is designed to hold a reverse acting gate valve in the fully open position. When temperature exceeds 400°F (204° C), the fusible element will soften allowing the valve to return to the fully closed position. Gate valve pressure is not necessary in forcing the valve to the closed position, as the actuator spring force provides sufficient force to close the gate valve. This fusible lock open device is adjustable and can be adapted to sizes of gate valves with strokes from 1¹³/₁₆" - 7¹/₁₆".

The Omni fusible lock open cap can be installed on any pneumatic or hydraulic actuators. This device can be used on 1¹³/₁₆" through 7¹/₁₆" gate valves with working pressures up to 10,000 psi.

CAUTION: Do not remove the fusible lock open device from an Omni actuator without an application of minimum operating pressure. Failure to perform this sequential operation could result in injury to personnel.

Note: This product is designed to meet API 6A latest edition section 10.20.2.5

Dimensions

A		B		Weight	
in	mm	in	mm	lbs	kg
5.60	142	4.00	102	11	5

Dimensions - Interface Thread

Item	in	mm
2.50 x 8 UN - 2B THD	2.50	64
3.00 x 8 UN - 2B THD	3.00	76

Parts List

Component	Description	Qty
1	Fusible Element	1
2	Adjustment Nut	1
3	Body	1
4	Retainer Plate	1
5	Socket Head Cap Screw	1

Specifications

Item	US	Metric
Fusible Temperature	400° F	204° C
Maximum Allowable Thrust	30,000 lbf.	133,447 N

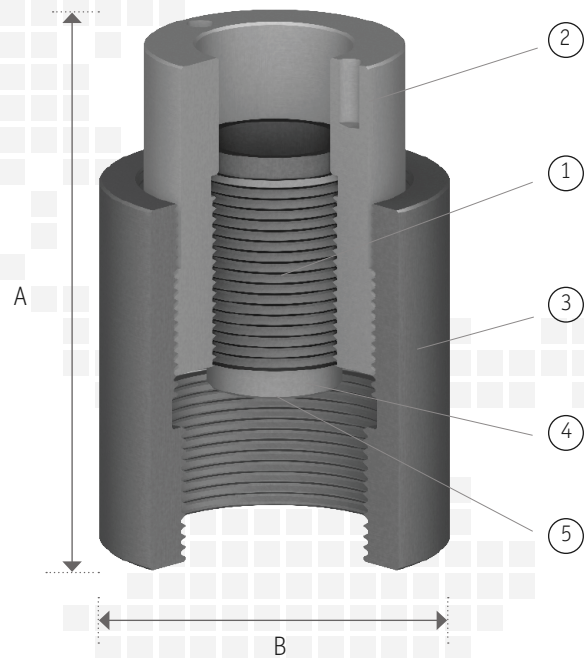

LIMIT SWITCH & POSITION INDICATOR

The Omni Limit Switch & Position Indicator assembly is designed to electronically monitor valve stroke position. This assembly can be adapted to either reverse or direct acting gate valves. This limit switch assembly is configured to accommodate a number of actuator and gate valve sizes. The assembly can be designed to adapt to all Omni pneumatic or hydraulic actuators.

Two ferrous components mechanically attached to the upper shaft, activate limit switches when the valve is in either the fully open or fully closed position. The switches may be adjusted to compensate for valve size and stroke. Dual windows are provided for monitoring of valve stroke. Protective coverings for viewing are manufactured of polycarbonate material.

The material construction for the leverless limit switch is 316 stainless steel. Housing construction and top plate are manufactured from carbon steel and coated for protection against severe service conditions.

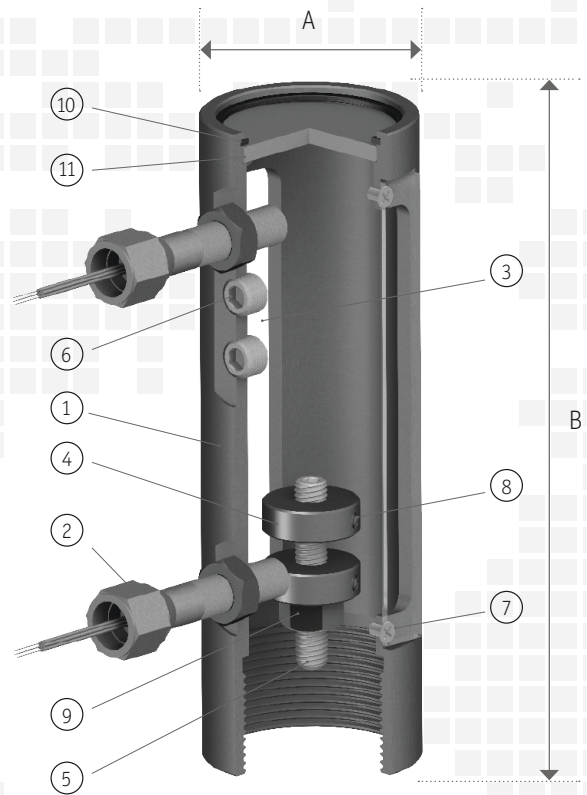

Dimensions

	A		B	
	in	mm	in	mm
2.50 – 8 UN – 2B THD	2.88	73	7.50	190
3.00 – 8 UN – 2B THD	3.38	86	10.25	260

Limit Switch Specifications

Specifications are for our standard switch. Omni offers a wide variety of switches that may exceed our stated "maximums" or differ from listed sensing range.

Maximum Voltage	120 VAC / 24 VDC
Maximum Amperage	4 AC / 3 DC
Contact Form	(SPDT) Single Pole Double Throw, Form C
Sensing Range	.100" (3mm)
Enclosure Material	316 Stainless Steel
Approvals	UL Class 1 - Div. 1, CSA Class 1 - Div. 1, ATEX Zone 1
Operating Temperature range	-40° to 221° F
Response Time	8 milliseconds
Suitable Zone Explosion Proof	0,1,2
Wiring Options	36" Leads – 18 Gauge Standard Greater lengths available in wire or cable upon request

Parts List

Component	Description	Qty
1	Housing	1
2	Switches	2
3	Window Shield	2
4	Switch Target	2
5	Stem Extension	1
6	Socket Set Screws	2
7	Flat Head Socket Screw	4
8	Socket Head Set Screw	2
9	Nut	1
10	Retainer Ring	1
11	Top Cover	1

HYDRAULIC CONTROL SOLUTIONS



HYDRAULIC CONTROL SOLUTIONS

Model EX - Self Contained Unit



Intro

The Omni Model EX is a self-contained hydraulic control system designed to control hydraulically-actuated reverse acting slab gate valves with a fail-safe mode of operation.

The system is rugged, compact and easy to access in a field service environment. Components are designed to perform well and provide years of trouble free service even in the harshest of operating conditions.

The system energizes the actuator using its own hydraulic fluid reservoir. There is no need for access to a hydraulic power source at the wellsite or wherever the actuated valve is deployed. This makes it ideally suited for deployment in remote locations or locations with limited power source options.

The system is energized by operating a hand pump and can be taken off line manually or automatically. Once the system is taken off-line it must be re-energized manually using the hand pump.

The Model EX system is most commonly deployed as a complete valve/actuator/control system package using Omni Valve's complete line of fail-safe hydraulic valves; however, the system can also be easily adapted to control hydraulic valves from any valve manufacturer.

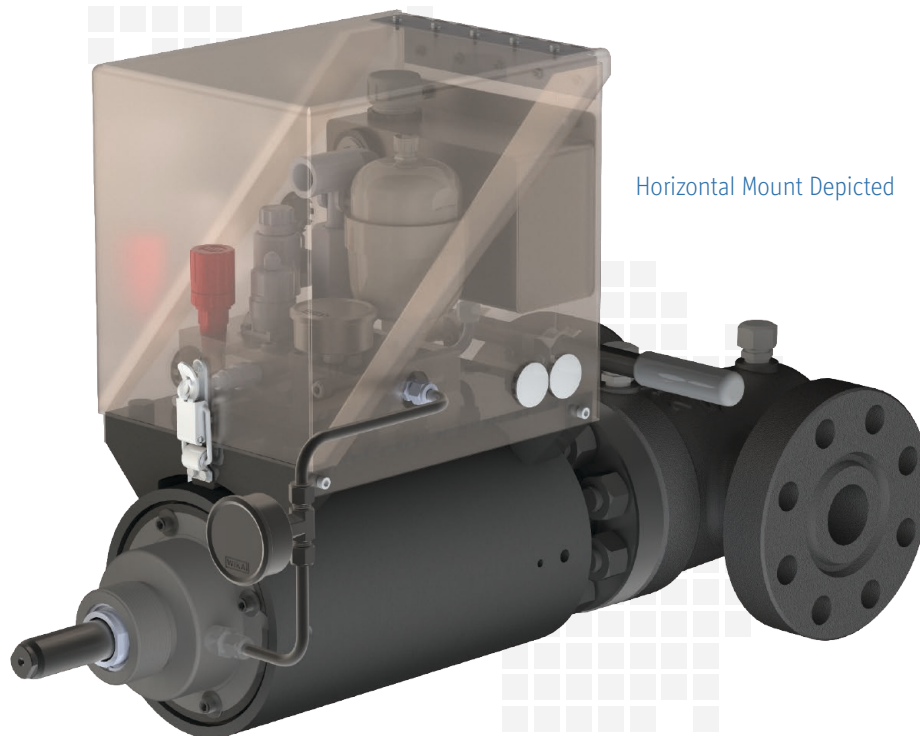

System Specifications

Temperature Range (°F)	-20 to 180
Reservoir Capacity (in ³)	120
Maximum Operating Pressure (psi)	3,000 (See Note)
HP Accumulator Capacity (in ³)	20
Pump Displacement (in ³)	0.38

Omni's standard pump displacement is 0.38 in³ but alternative displacements are available. Please contact Omni Valve for additional information

Note:

The Model EX comes standard with a machined aluminum block offering a maximum operating pressure of 3,000 psi. If actuator control pressure exceeding 3,000 psi but not to exceed 5,000 psi is required, the Model EX can be supplied with a machined steel manifold block.

HYDRAULIC CONTROL SOLUTIONS

Model EX - Self Contained Unit



Features

Manifold Block Design:

Model EX systems are constructed using a machined block style manifold for attachment of all required components. This eliminates the need to use pipe and compression fittings to connect the various system components to one another. The result is a system with fewer potential leak paths, a more compact space envelope and reduced sensitivity to vibration or other service or handling factors that might otherwise loosen connections between components and introduce leaks.

Fully Enclosed Cabinet with Locking Latch:

The Model EX system bolts directly onto the hydraulic valve actuator and is fully enclosed with a hinged cabinet that can be secured in the closed position and locked, if needed. This prevents damage to or loss of the cover after opening and ensures minimal infiltration of dirt, water, animals or other external irritants that could affect system performance.

Horizontal or Vertical Mounting:

The Model EX system can be used regardless of whether the actuated valve is mounted in the horizontal or vertical position in the field. In either case the system functions identically.

Multiple Pressure-Sensing & Control Configurations:

The Model EX system is capable of being configured in multiple ways depending on the pressure sensing and connectivity requirements of the wellsite.

Some options include:

- High or Low Pressure Pilots (or both)
- Solenoid Valve (12, 24 or other vdc electric)
- Combination of Pilots and Solenoid
- Internal/External or Both Pressure Gauges
- Connectivity to SCADA or Other Controls

Ease of Operation:

The Model EX system is designed to be easily taken off line or re-started with minimal training.

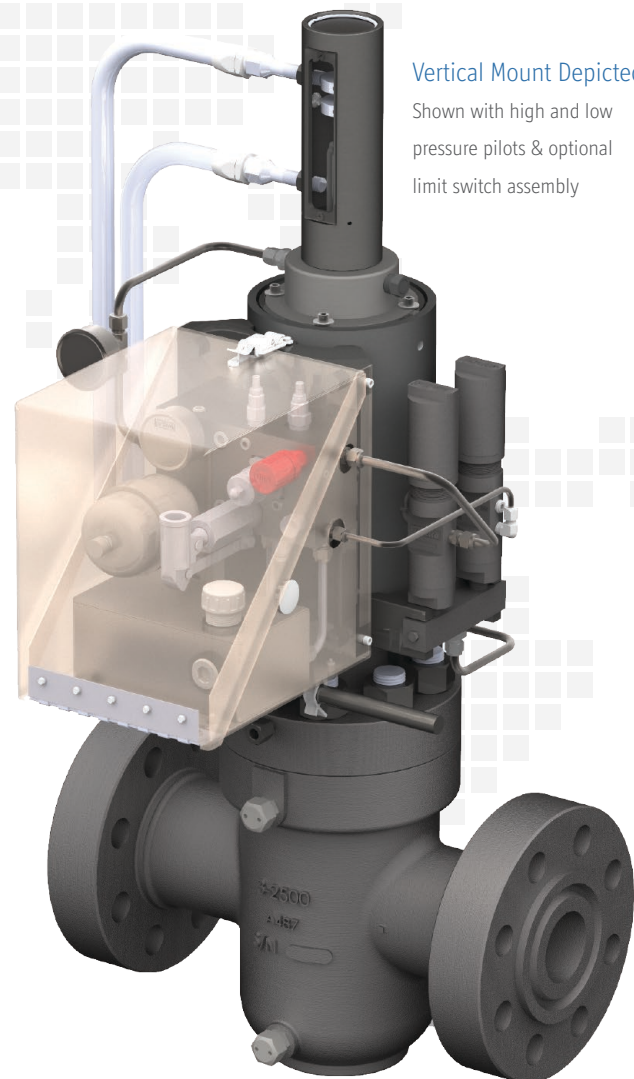

Vertical Mount Depicted

Shown with high and low pressure pilots & optional limit switch assembly

HYDRAULIC CONTROL SOLUTIONS

Model EX - Internal Configuration



The views below depict our standard configuration that employs an electronic solenoid for remote emergency shut down operation as well as a manual valve for local emergency shut down operations. This is the most common application for our EX unit. Many other configurations are available including: other methods of ESD devices, larger accumulators, eutectic fusible plugs. These various options may affect the appearance of the delivered product.

Depicted without cover to display internal components

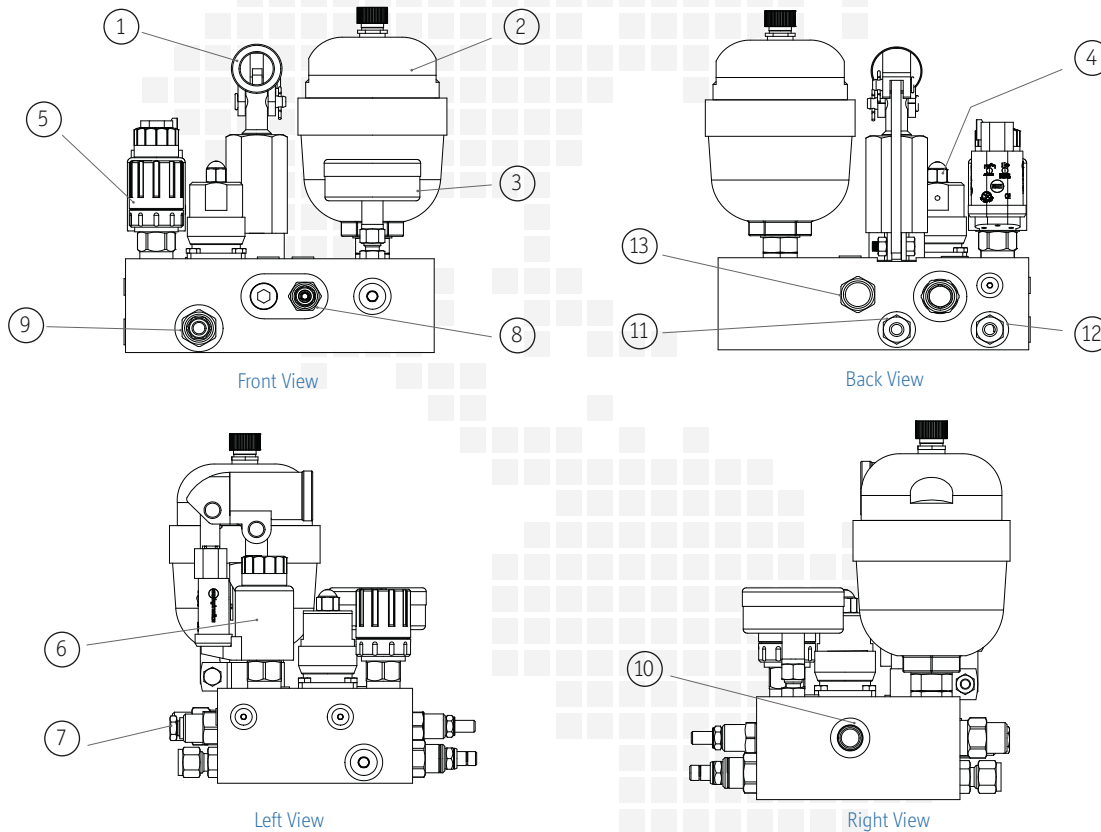

Item	Component	Description
1	Pump	A manual hydraulic pump used to build pressure in the system.
2	Accumulator	Uses pressurized gas to compensate system pressure for ambient temperature changes.
3	Gauge	Displays pressure of high pressure actuator line.
4	Regulator	Reduces pressure for use in pilot line.
5	Manual valve	Manual valve to trip the system.
6	Solenoid valve	Solenoid valve to trip the system.
7	Logic element	Holds pressure in the high pressure actuator line while pilot pressure is present.
8	Pressure relief	Relief to compensate for over pressurization due to ambient temperature increase.
9	Kick down	Allows pilot pressure to build on system start up. Used in place of manual priming valve.
10	Actuator port	Connection to hydraulic actuator.
11	Suction port	Connection to tank for pump suction.
12	Return Port	Connection to tank for system return
13	Filter	Filters the incoming hydraulic fluid

HYDRAULIC CONTROL SOLUTIONS

Model EX - Circuit Diagram

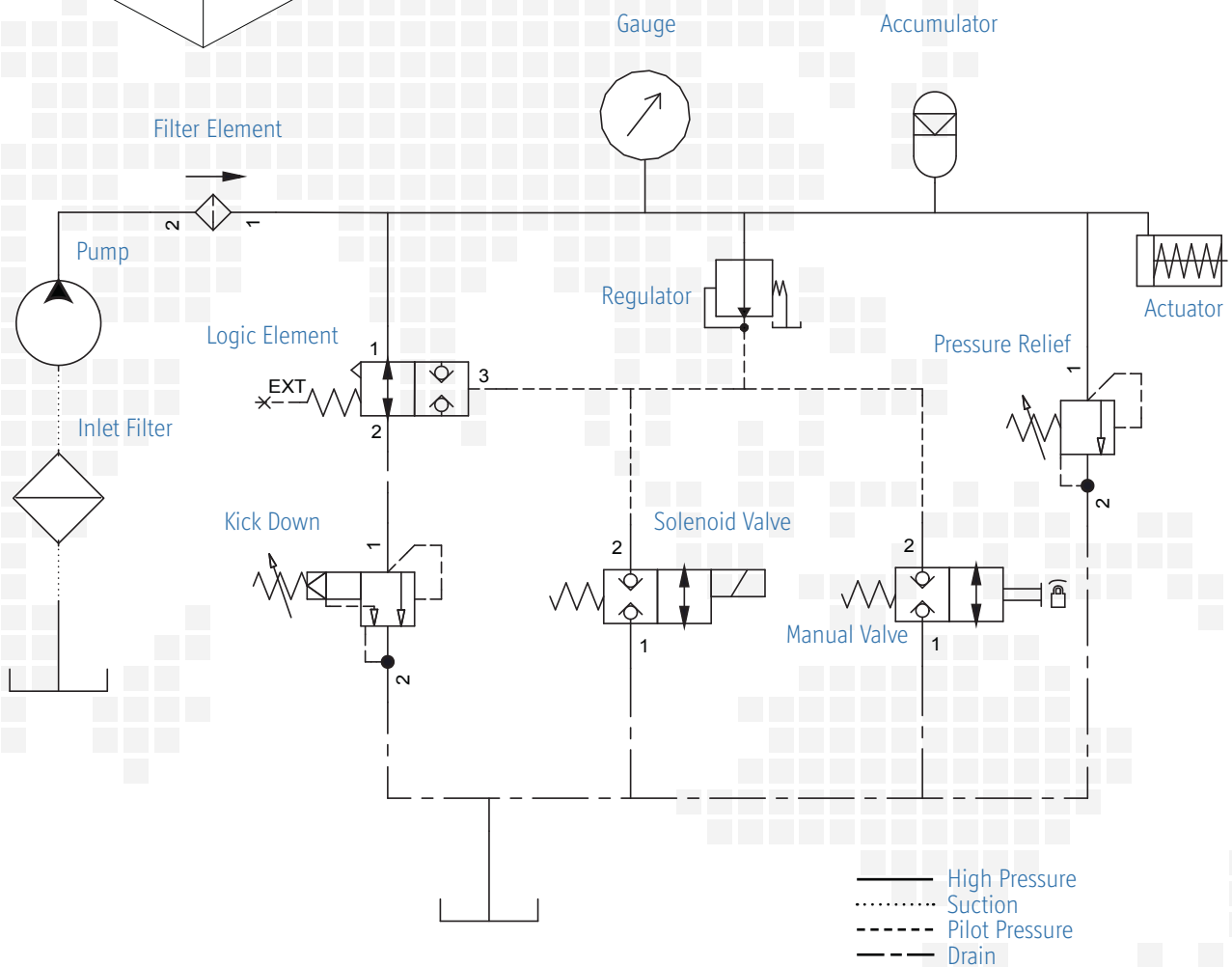
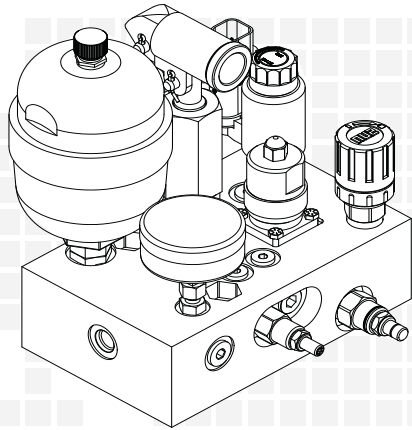

HYDRAULIC CONTROL SOLUTIONS

Model EX - Enclosure Dimensions

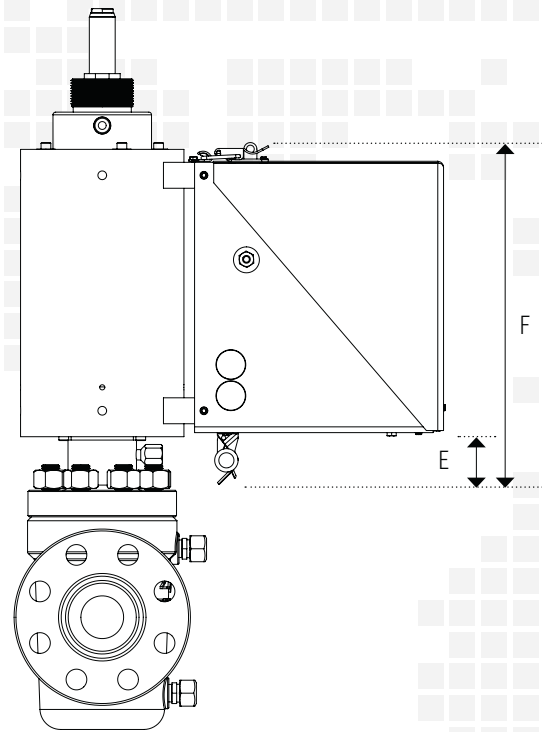
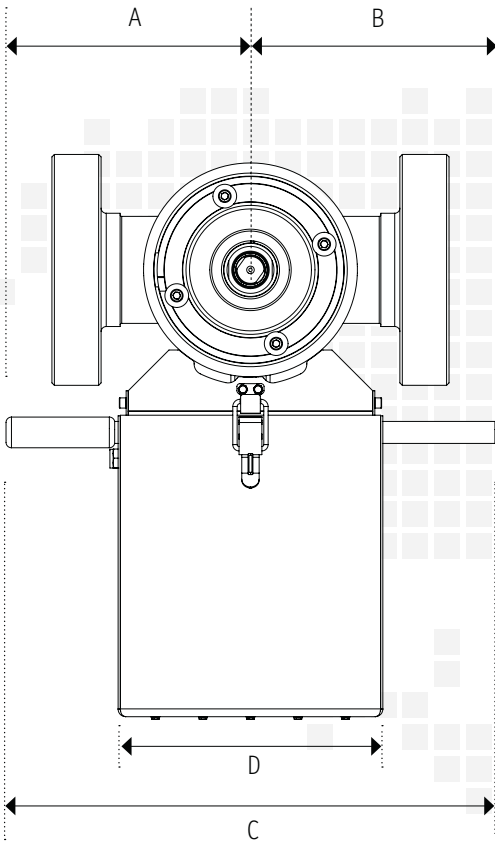

A	B	C	D	E	F
9 in	9 in	18 in	9.75 in	2.30 in	16.50 in

Model EX Shown with Pilots & Gauge

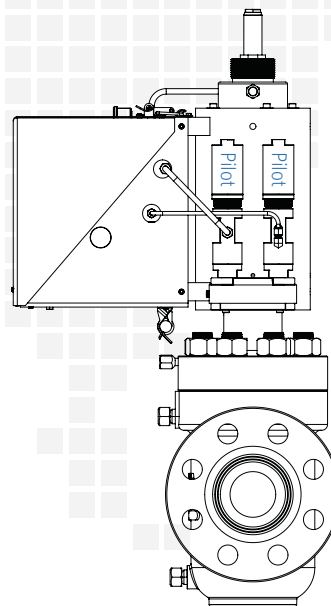
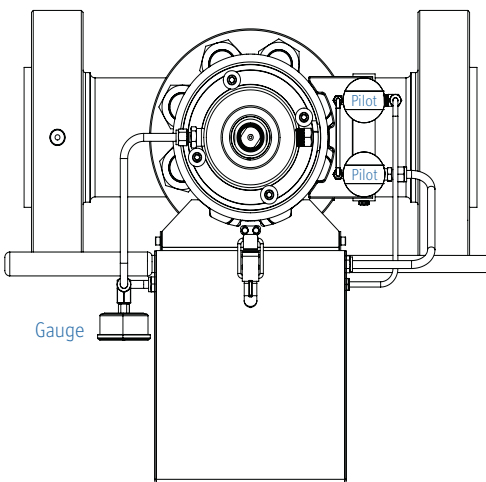

HYDRAULIC CONTROL SOLUTIONS

Model EX - Standard Omni Valve Dimensions

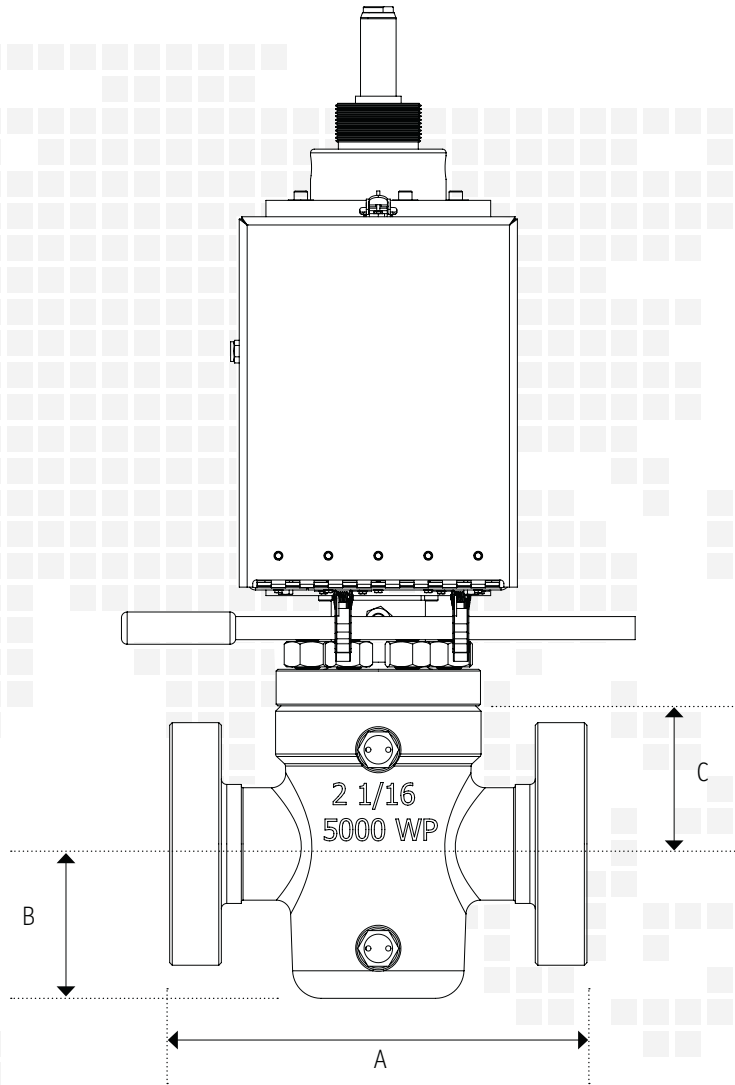

Size	Pressure	A		B		C	
		in	mm	in	mm	in	mm
2 1/16"	2,000	11.62	295	4.81	122	4.84	123
	3/5,000	14.62	371	5.06	129	4.84	123
2 9/16"	2,000	13.12	333	5.62	143	5.62	143
	3/5,000	16.62	422	5.93	151	5.62	143
3 1/8"	2,000	14.12	359	6.93	176	7.12	181
	3,000	17.12	435	7.31	186	7.12	181
	5,000	18.62	473	7.31	186	7.12	181
4 1/16"	2,000	17.12	435	8.62	219	8.32	211
	3,000	20.12	511	9.06	230	8.32	211
	5,000	21.62	549	9.06	230	8.32	211
5 1/8"	2,000	22.12	562	11.62	295	10.04	255
	3,000	24.12	613	11.62	295	10.04	255
	5,000	28.62	727	11.62	295	10.04	255
7 1/16"	2,000	26.12	663	13.87	352	12.86	327
	3,000	28.12	714	13.87	352	12.86	327
	5,000	32.00	813	13.87	352	12.86	327

Size	Pressure	A		B		C	
		in	mm	in	mm	in	mm
1 13/16"	10,000	18.25	464	5.69	145	3.88	99
	15,000	18.00	457	5.90	150	3.88	99
2 1/16"	10,000	20.50	521	5.69	145	3.88	99
	15,000	19.00	483	5.90	150	3.88	99
2 9/16"	10,000	22.25	565	6.75	171	4.70	119
	15,000	21.00	533	7.74	197	4.88	124
3 1/16"	10,000	24.38	619	8.12	206	5.61	142
	15,000	23.56	598	9.65	245	6.13	156
4 1/16"	10,000	26.38	670	10.19	259	7.23	184
	15,000	29.00	737	11.71	297	7.70	196



HYDRAULIC / PNEUMATIC



Actuators & Surface Safety Valves

OMNI VALVE

4520 Chandler Road | Muskogee, OK 74403 | USA

📞 918.687.6100

📠 918.687.6105

✉ sales@omnivalve.com

✓ quality@omnivalve.com

🔍 www.omnivalve.com

PRODUCT WARRANTY

All products quoted are subject to omni valve's

limited product warranty available at: omnivalve.com/warranty.shtml

